

HYDRONIC HIGH-WALL FAN COILS

INSTALLATION OPERATION AND

SERVICE MANUAL

SWC~EC SERIES



HARDI
Heating, Air-conditioning & Refrigeration Distributors International
PROUD MEMBER
2012 - 2013



INVESTING IN QUALITY, RELIABILITY & PERFORMANCE.

ISO 9001 QUALITY



Every product is manufactured to meet the stringent requirements of the internationally recognized ISO 9001 standard for quality assurance in design, development and production.

World Leading Design and Technology

Equipped with the latest CAD/CAM computer aided design and manufacturing technology, our factories in China and Thailand produce over 2,000,000 air conditioning units each year, all conforming to the highest international standards of quality and safety.

CE SAFETY STANDARDS



All products conform to the Certificate Europe directives (Machinery Safety, Electromagnetic Compatibility and Low Voltage), as required throughout the European Community, to guarantee correct standards of safety.

The Highest Standards of Manufacturing

In order to guarantee the very highest standards and performance, we manage every stage in the manufacturing of our products. Throughout the production process we maintain strict control, originating with our extensive resources in research and development through to the design and manufacture of almost every individual component, from molded plastics to the assembly of units and controllers.

WEEE MARK



All products conform to the "WEEE" directive to guarantee correct standards of environmental solutions.

Quality Controlled from Start to Finish

Our highly trained staff and strict quality control methods enable us to produce products with an exceptional reputation for reliability and efficiency, maintained over many years. As well as full CE certification and ISO 9001, several products have UL/CSA (NRTL) safety approval plus ARI Certification in the USA, ROHS compliance for Europe, giving you the confidence of knowing our company is the right choice when selecting air conditioning equipment.

ALWAYS MAKE SURE THIS MANUAL REMAINS WITH THE SWC-ECM WATER HIGH-WALL UNIT. READ THIS MANUAL BEFORE PERFORMING ANY OPERATION ON THE SWC-EC WATER HIGH-WALL UNIT.

Table of Content

MODEL CODE NOMENCLATURE.....	5
A. GENERAL DESCRIPTION.....	6
B. TECHNICAL DATA	7
B.1. GENERAL SPECIFICATION	7
B.1.1. SWC–V–EC Series 3-Speed Specifications	7
B.2. COIL DATA	9
B.2.1. 2-pipe systems	9
B.3. PERFORMANCE TABLES	10
B.3.1. Cooling Capacity Tables – 2-pipe systems.....	10
B.3.2. Heating Capacity Table – 2-pipe systems.....	14
B.4. DIMENSIONAL DRAWINGS	18
B.5. VALVE INFORMATION	20
B.5.1. 2-Way Valve Body	20
C. SERVICE AND INSTALLATION	21
C.1. INSTALLATION OF HIGH-WALL UNIT	21
C.1.1. Selecting a Location.....	21
C.1.2. Mounting Plate Dimensions.....	22
C.1.3. Installing the Mounting Plate.....	23
C.1.4. Drilling the Condensate Drainage Hole.....	23
C.1.5. Installing the Hydronic Unit	24
C.1.6. Drainage Piping Works	24
C.2. UNIT MAINTENANCES AND PREPARATIONS.....	25
C.2.1. Opening and Closing Of Lift-Up Grille Cover	25
C.2.2. Removing Front Cover Assembly.....	25
C.2.3. Air Purging	25
C.2.4. Wiring Connections	25
C.3. PIPE CONNECTIONS WITH VALVE.....	26
D. CONTROL SPECIFICATIONS.....	27
D.1. SK-NCSWC-001 COMPLETE FUNCTION FCU CONTROLLER.....	27
D.1.1. Abbreviations.....	27
D.1.2. Definition of Input/Output.....	27
D.1.3. Wiring Diagram SK-NCSWC-001	28
D.1.4. Configuration Settings	29
D.1.5. Control Logics For 2-Pipe System	31
D.1.6. Control Logics For 4-Pipe System	35
D.1.7. Auto Fan Speed	38
D.1.8. Louver	39
D.1.9. Buzzer	39
D.1.10. Auto Restart.....	39
D.1.11. Operation Of Control Panel On High-Wall Unit.....	40
D.2. LED LIGHTS.....	41
D.2.1. LED Indication and Error Description.....	42
D.2.2. LED indication on Master/Slave connection	43
D.3. NETWORKING SYSTEM	44
D.3.1. Master-Slave Network.....	44
D.3.2. Master – Slave Network Setup.....	45
D.3.3. Master-Slave Communication Method.....	48
D.3.4. Unit Network Wiring Scheme.....	49
D.4. SK-NCSWC-002 LIMITED FUNCTION FCU CONTROLLER	50
D.4.1. Definition of Input/Output.....	50
D.4.2. Wiring diagram SK-NCSWC-002	51
D.4.3. Onboard configuration	52

D.4.4.	Control Logics.....	52
D.4.5.	LED Indication	53
D.4.6.	Error Description	53
D.5.	OPEN MODBUS PROTOCOL.....	54
E.	USERS INTERFACE	58
E.1.	REMOTE CONTROL HANDSET	58
E.2.	WIRED WALL PAD	59
E.2.1.	Wall Pad Display.....	59
E.2.2.	Wall Pad Operation Guidelines	60
E.2.3.	EC unit RPM setting.....	63
E.3.	SENSOR RESISTANCE R-T CONVERSION TABLE.....	64
E.4.	TROUBLESHOOTING GUIDE.....	66

Model Code Nomenclature

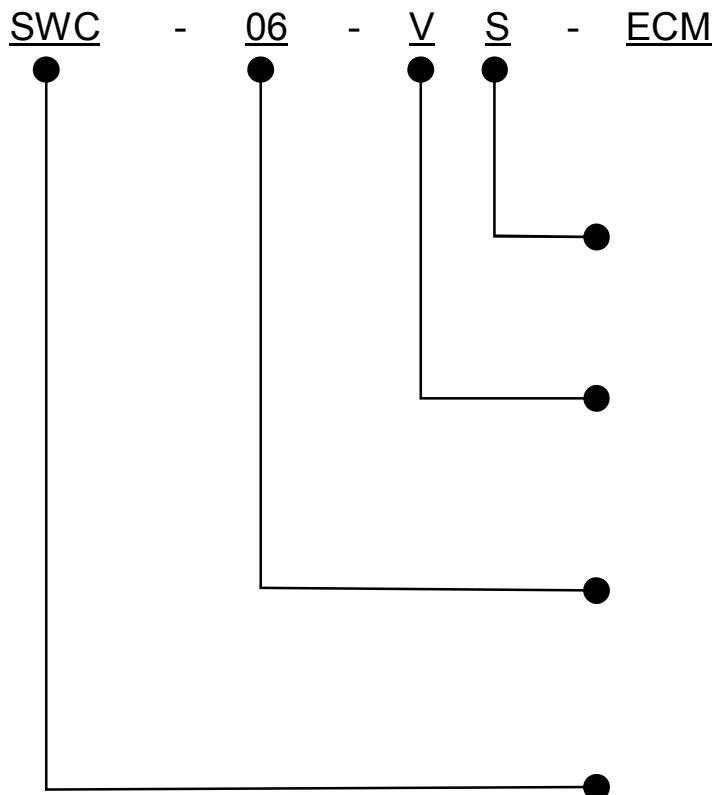

ECM	EC motor configuration
-----	------------------------

S	Complete function onboard PCB with integrated group control functionality.
W	Limited function onboard PCB with drain-pump, louver and zone control functionality.

V	2-pipe system
---	---------------

04	Model. See General Specification (section B) for cooling/heating Sizes capacities
06	
12	
15	
18	
24	

SWC	Hydronic high-wall C Series
-----	-----------------------------

A. General Description

This High-Wall Unit is designed to meet and exceed demanding requirements for efficiency, quiet operation and good looks. The sleek profile and elegantly styled cabinet complements any interior design theme, and the microprocessor assures accurate environmental control.

Cabinet ~ the cosmetically attractive cabinet is constructed of durable flame resistant acrylonitrile-butadiene-styrene (ABS) plastic. The silver white color and rounded corners provide its contemporary appearance.

Water Coil ~ the water coil has a large heat transfer surface and utilizes the latest technology in fin profile. It combines an advanced technology approach with the security of a traditional tube thickness design. The water coil is also equipped with an air vent valve and a water purge valve.

Integral Hoses ~ an integral hose is a synthetic elastomer tube, with stainless steel outer braiding and brass connectors, which enables quick, low cost connections with no brazing.

Blower and Motor ~ the High-wall unit incorporates only specially designed and tested high power-factor, permanent split capacitor type blower motors, allowing the tangential blower wheel to provide optimum performance in airflow-efficiency and quiet operation.

Filters ~ washable, easy-to-remove, fine mesh air filters are standard to all High-wall models. Tabs located on the front of the unit can be unsnapped, allowing the filter to be easily slid downward and removed. No tools are required, nor are dismantling of any equipment.

Air Grille Distribution ~ all High-wall units are equipped with both deflector blades and independent directional vanes, enabling supply air to be automatically distributed, and air flow and direction customized.

Microprocessor Control ~ see **D. Controls Specifications** (pages 27 - 54) for complete control specifications and details. The main design features include:

- ~ FCEER rating class: A/B.
- ~ FCCOP rating class: B/C.
- ~ High efficiency brushless DC motor with PID algorithmic processing in auto-mode.
- ~ 2-pipe, 2-pipe and booster electric heat, 2-pipe and primary electric heat, 4-pipe with 4x2 device installed.
- ~ Cool, Heat, Auto, Dehumidifier and Fan modes.
- ~ Sleep, Auto-Fan, Daily Timer, Auto-Restart with memory functions.
- ~ User friendly remote control handset.
- ~ Heat and cool temperature protections and safety cut out.
- ~ 2-way and 3-way on/off valve control.
- ~ Addressable control and error diagnostics (Master-Slave) for sub-networks of up to 32 units, with IR handset as global control interface.
- ~ Wired wall pad controller (optional) with 7-day programmable timer, real-time clock, network control (global and addressable) and error diagnostics.
- ~ Manual control panel in cabinet.
- ~ Auxiliary switch for cooling and heating signal.
- ~ Occupancy (remote on/off) contacts / economy mode contacts.
- ~ Open Modbus communication protocol.
- ~ Local PC host control solution (optional).

B. Technical Data

B.1. General Specification

B.1.1. SWC-V-EC Series 3-Speed Specifications

Product range: SWC-ECM Hydronic High Wall with EC Motor

SWC-V-ECM Hydronic High Wall 2-pipe with EC Motor



		SWC-[Size]-V-ECM		04	06	12	15	
Unit Configuration	Configuration		2-pipe					
	Number Of Fan Blowers		Single					
	Power Supply	(V/Ph/H z)	230/1/50 220/1/60					
	Operation Control		~S: Complete function onboard PCB with integrated group control functionality, incl. 1 pc return air sensor and 2 pcs temperature sensors. ~W: Limited function onboard PCB with drain-pump, louver and zone control functionality, incl. 1 pc coil temperature sensors.					
Performance Data	Air	Total Air Flow ^e	H	m ³ /hr	370	500	500	645
			M	290	370	370	445	
			L	220	290	290	370	
	Cooling	Cooling Capacity ^e	H	kW	1.31	2.17	2.59	3.16
			M		1.09	1.71	2.03	2.36
			L		0.88	1.43	1.68	2.03
		Sensible Cooling Capacity ^e	H		0.97	1.59	1.88	2.31
			M		0.80	1.25	1.46	1.71
			L		0.64	1.04	1.2	1.46
	FCEER ^e	Rating	142	175	207	192		
		Class	B	B	A	A		
	Heating	Heating Capacity ^e	H	kW	1.60	2.64	3.12	3.83
			M		1.33	2.08	2.44	2.83
			L		1.06	1.71	1.98	2.44
		Max. Electric Heater Capacity	0.6			1.2		
	FCCOP ^e	Rating	172	211	246	232		
		Class	B	B	B	B		
	Sound	Sound PressureLevel (Outlet)		dB(A)	27/24/21		35/27/24	
		Sound Power Level (Outlet) ^e			38/35/32		46/38/35	
	Electrical	Fan Motor Power ^e	H	W	10	13	13	20
M			8		10	10	13	
L			6		8	8	10	
Fan Motor Apparent Power @ H		20			32	50		
Fan Motor Running Current @ H	0.08			0.142	0.142	0.182		
Hydraulic	Cooling Water Flow Rate	H	L/h	225	370	446	543	
		M		187	294	348	406	
		L		150	244	288	348	
	Cooling Pressure Drop ^e	H	kPa	10.1	12	10	14.1	
		M		7.4	8.06	6.62	8.58	
		L		5.1	5.9	4.8	6.62	
	Heating Water Flow Rate @H/M/L		L/h					
			Same as "Cooling Water Flow Rate"					
Heating Pressure Drop ^e	H	kPa	9	9	11	12		
	M		4.5	4.5	7	7		
	L		3.5	3.5	4	5		
Water Content		L		0.045	0.0789	0.124	0.124	
Construction and Packing Data	Water Connections	Type	Socket (Threaded Female)					
		In	12.70 [1/2]					
	Out	16 [0.63]						
	Condensate Drainage Connection		16 [0.63]					
	Dimensions	L	mm	876				
		W		228				
H		300						
Net Weight		Kg		11	12	13	13	

1."e" refers to technical information listed on the Eurovent website. Eurovent testing conditions:

a. Cooling mode (2-pipe):

- Return air temperature: 27C DB/ 19C WB.
- Inlet/ outlet water temperature: 7C/ 12C.
- Water flow-rate: variable.

b. Heating mode (2-pipe):

- Return air temperature: 20C.
- Inlet water temperature: 50C.
- Water flow-rate: same as 2-pipe cooling.

Product range: SWC-ECM Hydronic High Wall with EC Motor



SWC-V--ECM Hydronic High Wall 2-pipe with EC Motor

		SWC-[Size]-V--ECM		18	20	24	
Unit Configuration	Configuration		2-pipe				
	Number Of Fan Blowers		Single				
	Power Supply	(V/Ph/Hz)	230/1/50 220/1/60				
	Operation Control		~S: Complete function onboard PCB with integrated group control functionality, incl. 1 pc return air sensor and 2 pcs temperature sensors. ~W: Limited function onboard PCB with drain-pump, louver and zone control functionality, incl. 1 pc coil temperature sensors.				
Performance Data	Air	Total Air Flow ^e	H	m ³ /hr	876	980	1240
			M		740	760	1080
			L		570	600	760
	Cooling	Cooling Capacity ^e	H	kW	4.38	5.19	6.25
			M		3.84	4.23	5.61
			L		3.12	3.50	4.23
		Sensible Cooling Capacity ^e	H		3.18	3.73	4.52
			M		2.78	3.03	4.04
			L		2.24	2.49	3.03
	FCEER ^e	Rating Class		213	180	126	
	Heating	Heating Capacity ^e	H	kW	5.25	6.14	7.44
			M		4.58	4.97	6.65
			L		3.68	4.09	4.97
		Max. Electric Heater Capacity			1.6		
	FCCOP ^e	Rating Class		255	212	153	
	Sound	Sound PressureLevel (Outlet)		dB(A)	46/40/34	41/35/30	48/45/35
		Sound Power Level (Outlet) ^e			57/51/45	52/46/41	59/56/46
	Electrical	Fan Motor Power ^e	H	W	30	45	83
			M		20	24	60
			L		13	18	24
		Fan Motor Apparent Power @ H			83	90	200
	Fan Motor Running Current @ H		A	0.272	0.4	0.75	
	Hydraulic	Cooling Water Flow Rate	H	L/h	752	889	1072
			M		658	727	961
L			536		601	727	
Cooling Pressure Drop ^e		H	kPa	19.4	19.8	27.2	
		M		15.5	14	22.6	
		L		10.8	10.1	14	
Heating Water Flow Rate @H/M/L		L/h	Same as "Cooling Water Flow Rate"				
Heating Pressure Drop ^e	H	kPa	16	16	25		
	M		13	12	19		
	L		8	8	13		
Water Content		L	0.192	0.252	0.252		
Construction and Packing Data	Water Connections	Type		Socket (Threaded Female)			
		In	mm [in]	12.70 [1/2]			
	Out	16 [0.63]					
	Condensate Drainage Connection		16 [0.63]				
	Dimensions	L	mm	876	1063		
		W		228	240		
H		300		310			
Net Weight		Kg	14	16	16		

1."e" refers to technical information listed on the Eurovent website. Eurovent testing conditions:

a. Cooling mode (2-pipe):

- Return air temperature: 27C DB/ 19C WB.
- Inlet/ outlet water temperature: 7C/ 12C.
- Water flow-rate: variable.

b. Heating mode (2-pipe):

- Return air temperature: 20C.
- Inlet water temperature: 50C.
- Water flow-rate: same as 2-pipe cooling.

B.2. Coil Data

B.2.1. 2-pipe systems

Model	Fin Height (mm.)	Fin Length (mm.)	Fins per Inch	No. of Rows	No. of Copper	No. of Circuits	Tube Diameter (mm)
SWC-04	230	680	19.5	2	8	2	7
SWC-06	357	680		2	20	4	7
SWC-12	357	680		2	26	5	7
SWC-15	357	680		2	26	5	7
SWC-18	357	680		2	34	5	7
SWC-20	378	845		2	36	6	7
SWC-24	378	845		2	36	6	7

B.3. Performance Tables

B.3.1. Cooling Capacity Tables – 2-pipe systems

SWC-04-V-ECM

		TAI DB24°C-WB17.4°C						TAI DB27°C-WB19°C						TAI DB27°C-WB19.5°C						TAI DB28°C-WB21°C					
Twi	qa	Pf	Pfs	Tad	Taw	dPw	Qw	Pf	Pfs	Tad	Taw	dPw	Qw	Pf	Pfs	Tad	Taw	dPw	Qw	Pf	Pfs	Tad	Taw	dPw	Qw
°C	m3/h	kW	kW	°C	°C	kPa	l/s	kW	kW	°C	°C	kPa	l/s	kW	kW	°C	°C	kPa	l/s	kW	kW	°C	°C	kPa	l/s
5	370	1.3	0.913	16.1	13.3	10.1	0.0618	1.58	1.09	17.5	14.2	14.1	0.0754	1.68	1.09	17.5	14.5	15.6	0.08	1.97	1.15	18	15.4	20.7	0.094
	290	1.08	0.757	15.7	13	7.36	0.0514	1.31	0.902	17	13.9	10.3	0.0626	1.39	0.902	17	14.1	11.4	0.0664	1.64	0.95	17.4	15	15	0.078
	220	0.867	0.605	15.1	12.7	5.07	0.0413	1.05	0.72	16.3	13.4	7.06	0.056	1.12	0.721	16.3	13.7	7.8	0.0532	1.31	0.759	16.7	14.5	10.2	0.0624
7	370	1.02	0.793	17.2	14.2	6.6	0.0487	1.31	0.971	18.6	15.1	10.1	0.0625	1.41	0.971	18.6	15.4	11.4	0.0671	1.7	1.03	19	16.2	15.8	0.0813
	290	0.853	0.658	16.8	14	4.86	0.0407	1.09	0.804	18.1	14.8	7.4	0.052	1.17	0.804	18.1	15.1	8.33	0.0559	1.42	0.853	18.5	15.9	11.5	0.0675
	220	0.687	0.526	16.2	13.7	2.04	0.0328	0.877	0.642	17.4	14.5	5.1	0.0418	0.94	0.642	17.4	14.7	5.73	0.0448	1.13	0.681	17.8	15.5	7.89	0.0541
9	370	0.721	0.67	18.2	15.2	3.6	0.0344	1.02	0.85	19.6	16	6.44	0.0485	1.11	0.851	19.6	16.3	7.54	0.0532	1.41	0.91	20.1	17.1	11.3	0.0675
	290	0.604	0.556	17.9	15	1.7	0.0288	0.849	0.705	19.2	15.8	4.75	0.0405	0.93	0.705	19.2	16	5.54	0.0444	1.18	0.754	19.6	16.8	8.28	0.0562
	220	0.49	0.445	17.4	14.8	1.37	0.0234	0.684	0.563	18.6	15.5	3.3	0.0327	0.749	0.563	18.6	15.7	3.84	0.0357	0.945	0.603	19	16.5	5.7	0.0451
Pf: total cooling capacity Tal: in flow air temperature dpw: pressure drop standard coil Twi: entering water temperature, water temperature arise 5°C.																									
Qw: fluid flow rate in heat exchanger Qa: air flow Pfs: sensible cooling capacity Tad: discharge air dry temperature Taw: discharge air wet temperature																									

SWC-06-V-ECM

		TAI DB24°C-WB17.4°C						TAI DB27°C-WB19°C						TAI DB27°C-WB19.5°C						TAI DB28°C-WB21°C					
Twi	qa	Pf	Pfs	Tad	Taw	dPw	Qw	Pf	Pfs	Tad	Taw	dPw	Qw	Pf	Pfs	Tad	Taw	dPw	Qw	Pf	Pfs	Tad	Taw	dPw	Qw
°C	m3/h	kW	kW	°C	°C	kPa	l/s	kW	kW	°C	°C	kPa	l/s	kW	kW	°C	°C	kPa	l/s	kW	kW	°C	°C	kPa	l/s
5	500	2.14	1.5	14.4	12.3	12	0.102	2.61	1.79	15.4	13	16.8	0.124	2.77	1.79	15.4	13.2	18.6	0.132	3.25	1.88	15.8	13.9	24.5	0.155
	370	1.71	1.19	13.7	11.9	8.14	0.0814	2.07	1.42	14.7	12.5	11.3	0.0989	2.2	1.42	14.7	12.7	12.5	0.105	2.58	1.49	15	13.4	16.4	0.123
	290	1.41	0.978	13.2	11.5	5.87	0.0672	1.71	1.16	14.1	12.1	8.14	0.0814	1.81	1.16	14.1	12.3	8.98	0.0862	2.12	1.22	14.4	12.9	11.7	0.101
7	500	1.69	1.3	15.6	13.4	7.9	0.0808	2.17	1.59	16.7	14.1	12	0.103	2.33	1.59	16.7	14.3	13.6	0.111	2.81	1.69	17.1	15	18.8	0.134
	370	1.36	1.03	15.1	13.1	5.41	0.0646	1.71	1.25	16	13.7	8.06	0.0817	1.85	1.26	16	13.9	9.2	0.0884	2.23	1.34	16.4	14.5	12.7	0.107
	290	1.12	0.85	14.6	12.8	3.93	0.0535	1.43	1.04	15.5	13.4	5.9	0.068	1.53	1.04	15.5	13.6	6.63	0.0729	1.84	1.1	15.8	14.1	9.09	0.0877
9	500	1.2	1.1	16.9	14.6	4.33	0.0573	1.69	1.4	18	15.2	7.72	0.0805	1.85	1.4	18	15.5	9.02	0.0882	2.34	1.5	18.3	16.1	13.5	0.112
	370	0.967	0.874	16.5	14.4	1.82	0.0461	1.35	1.11	17.4	14.9	5.29	0.0644	1.48	1.11	17.4	15.1	6.16	0.0705	1.86	1.19	17.7	15.7	9.16	0.0889
	290	0.805	0.719	16.1	14.2	1.52	0.0384	1.12	0.908	16.9	14.7	3.85	0.0534	1.22	0.91	16.9	14.8	4.47	0.0583	1.54	0.973	17.2	15.4	6.6	0.0734
Pf: total cooling capacity Tal: in flow air temperature dpw: pressure drop standard coil Twi: entering water temperature, water temperature arise 5°C.																									
Qw: fluid flow rate in heat exchanger Qa: air flow Pfs: sensible cooling capacity Tad: discharge air dry temperature Taw: discharge air wet temperature																									

SWC-12-V-ECM

		TAI DB24°C-WB17.4°C						TAI DB27°C-WB19°C						TAI DB27°C-WB19.5°C						TAI DB28°C-WB21°C					
Twi	qa	Pf	Pfs	Tad	Taw	dPw	Qw	Pf	Pfs	Tad	Taw	dPw	Qw	Pf	Pfs	Tad	Taw	dPw	Qw	Pf	Pfs	Tad	Taw	dPw	Qw
°C	m3/h	kW	kW	°C	°C	kPa	l/s	kW	kW	°C	°C	kPa	l/s	kW	kW	°C	°C	kPa	l/s	kW	kW	°C	°C	kPa	l/s
5	500	2.56	1.78	12.6	11.2	9.98	0.122	3.1	2.11	13.3	11.7	13.9	0.148	3.29	2.11	13.3	11.8	15.3	0.157	3.85	2.22	13.6	12.4	20.1	0.183
	370	2.02	1.4	12	10.7	6.69	0.0964	2.45	1.66	12.6	11.2	9.24	0.117	2.59	1.66	12.6	11.3	10.2	0.123	3.03	1.75	12.8	11.8	13.3	0.144
	290	1.66	1.14	11.4	10.4	4.77	0.079	2	1.35	12	10.7	6.56	0.0953	2.12	1.35	12	10.9	7.22	0.101	2.47	1.42	12.2	11.3	9.39	0.118
7	500	2.04	1.54	14.1	12.6	6.65	0.0971	2.59	1.88	14.8	13	10	0.124	2.78	1.88	14.8	13.2	11.3	0.132	3.34	2	15.1	13.7	15.5	0.159
	370	1.62	1.21	13.5	12.2	4.5	0.0771	2.03	1.46	14.1	12.6	6.62	0.0968	2.19	1.48	14.2	12.7	7.54	0.105	2.63	1.57	14.4	13.2	10.3	0.126
	290	1.33	0.991	13.1	11.9	2	0.0634	1.68	1.2	13.6	12.2	4.8	0.0801	1.8	1.21	13.6	12.4	5.38	0.0857	2.15	1.28	13.8	12.8	7.32	0.103
9	500	1.46	1.3	15.6	14	3.71	0.0695	2.03	1.65	16.3	14.4	6.51	0.0968	2.22	1.65	16.3	14.6	7.58	0.106	2.79	1.77	16.6	15	11.2	0.133
	370	1.16	1.03	15.2	13.7	1.66	0.0555	1.61	1.3	15.7	14.1	4.4	0.0769	1.76	1.3	15.7	14.2	5.11	0.84	2.21	1.39	15.9	14.6	7.52	0.105
	290	0.963	0.837	14.8	13.5	1.37	0.0459	1.33	1.06	15.3	13.8	1.9	0.0633	1.45	1.06	15.2	13.9	3.67	0.069	1.81	1.13	15.4	14.2	5.36	0.083
Pf: total cooling capacity Tal: in flow air temperature dpw: pressure drop standard coil Twi: entering water temperature, water temperature arise 5°C.																									
Qw: fluid flow rate in heat exchanger Qa: air flow Pfs: sensible cooling capacity Tad: discharge air dry temperature Taw: discharge air wet temperature																									

SWC-15-V-ECM

		TAI DB24°C-WB17.4°C						TAI DB27°C-WB19°C						TAI DB27°C-WB19.5°C						TAI DB28°C-WB21°C					
Twi	qa	Pf	Pfs	Tad	Taw	dPw	Qw	Pf	Pfs	Tad	Taw	dPw	Qw	Pf	Pfs	Tad	Taw	dPw	Qw	Pf	Pfs	Tad	Taw	dPw	Qw
°C	m3/h	kW	kW	°C	°C	kPa	l/s	kW	kW	°C	°C	kPa	l/s	kW	kW	°C	°C	kPa	l/s	kW	kW	°C	°C	kPa	l/s
5	645	3.12	2.18	13.2	11.5	14	0.149	3.79	2.59	14	12.1	19.6	0.181	4.02	2.59	14	12.3	21.6	0.192	4.71	2.73	14.3	12.9	28.5	0.225
	445	2.34	1.62	12.4	11	8.54	0.111	2.83	1.92	13.1	11.5	11.8	0.135	3	1.92	13.1	11.6	13.1	0.143	3.51	2.02	13.3	12.1	17.1	0.167
	370	2.02	1.4	12	10.7	6.69	0.0964	2.45	1.66	12.6	11.2	9.24	0.117	2.59	1.66	12.6	11.3	10.2	0.123	3.03	1.75	12.8	11.8	13.3	0.144
7	645	2.47	1.89	14.6	12.9	9.26	0.118	3.16	2.31	15.4	13.4	14.1	0.151	3.39	2.31	15.4	13.6	15.9	0.161	4.08	2.45	15.7	14.1	21.9	0.195
	445	1.86	1.41	13.9	12.4	5.71	0.0888	2.36	1.71	14.6	12.9	8.58	0.113	2.53	1.72	14.6	13	9.65	0.121	3.05	1.82	14.8	13.5	13.2	0.145
	370	1.62	1.21	13.5	12.2	4.5	0.0771	2.03	1.46	14.1	12.6	6.62	0.0968	2.19	1.48	14.2	12.7	7.54	0.105	2.63	1.57	14.4	13.2	10.3	0.126
9	645	1.76	1.6	16.1	14.2	5.1	0.0839	2.46	2.02	16.8	14.7	9.06	0.118	2.7	2.02	16.8	14.9	10.6	0.129	3.41	2.17	17.1	15.4	15.8	0.162
	445	1.34	1.19	15.5	13.9	1.9	0.0637	1.86	1.5	16.1	14.3	5.6	0.0886	2.03	1.5	16.1	14.4	6.5	0.0968	2.55	1.61	16.3	14.9	9.62	0.122
	370	1.16	1.03	15.2	13.7	1.66	0.0555	1.61	1.3	15.7	14.1	4.4	0.0769	1.76	1.3	15.7	14.2	5.11	0.084	2.21	1.39	15.9	14.6	7.52	0.105

Pf: total cooling capacity Tal: in flow air temperature dpw: pressure drop standard coil Twi: entering water temperature, water temperature arise 5°C.

Qw: fluid flow rate in heat exchanger Qa: air flow Pfs: sensible cooling capacity Tad: discharge air dry temperature Taw: discharge air wet temperature

SWC-18-V-ECM

		TAI DB24°C-WB17.4°C						TAI DB27°C-WB19°C						TAI DB27°C-WB19.5°C						TAI DB28°C-WB21°C					
Twi	qa	Pf	Pfs	Tad	Taw	dPw	Qw	Pf	Pfs	Tad	Taw	dPw	Qw	Pf	Pfs	Tad	Taw	dPw	Qw	Pf	Pfs	Tad	Taw	dPw	Qw
°C	m3/h	kW	kW	°C	°C	kPa	l/s	kW	kW	°C	°C	kPa	l/s	kW	kW	°C	°C	kPa	l/s	kW	kW	°C	°C	kPa	l/s
5	876	4.33	3	13	11.4	19.3	0.206	5.25	3.57	13.8	12	26.9	0.25	5.56	3.57	13.8	12.2	29.7	0.265	6.51	3.76	14.1	12.7	39	0.31
	740	3.79	2.62	12.6	11.2	15.4	0.181	4.59	3.11	13.4	11.7	21.3	0.219	4.86	3.12	13.4	11.9	23.5	0.232	5.68	3.28	13.7	12.4	30.8	0.271
	570	3.08	2.12	12.1	10.8	10.8	0.147	3.72	2.51	12.7	11.2	14.9	0.177	3.94	2.51	12.7	11.4	16.4	0.188	4.6	2.65	13	11.9	21.4	0.219
7	876	3.45	2.61	14.4	12.7	12.9	0.164	4.38	3.18	15.2	13.2	19.4	0.209	4.7	3.18	15.2	13.4	21.9	0.224	5.65	3.38	15.5	14	30.1	0.27
	740	3.03	2.28	14	12.5	10.3	0.144	3.84	2.78	14.9	13	15.5	0.183	4.11	2.78	14.9	13.2	17.4	0.196	4.94	2.95	15.1	13.7	23.9	0.236
	570	2.47	1.84	13.6	12.2	7.26	0.118	3.12	2.24	14.3	12.6	10.8	0.149	3.34	2.24	14.3	12.8	12.2	0.159	4	2.38	14.5	13.2	16.6	0.191
9	876	2.47	2.21	15.9	14.1	7.18	0.118	3.44	2.79	16.7	14.6	12.6	0.164	3.76	2.79	16.7	14.7	14.7	0.179	4.73	2.99	17	15.2	21.8	0.226
	740	2.18	1.93	15.7	14	5.79	0.104	3.02	2.44	16.4	14.4	10.1	0.144	3.3	2.44	16.4	14.5	11.7	0.157	4.14	2.61	16.6	15	17.3	0.198
	570	1.78	1.56	15.2	13.7	4.13	0.0852	2.46	1.97	15.8	14.1	7.12	0.117	2.68	1.97	15.8	14.2	8.26	0.128	3.36	2.11	16	14.6	12.1	0.16

Pf: total cooling capacity Tal: in flow air temperature dpw: pressure drop standard coil Twi: entering water temperature, water temperature arise 5°C.

Qw: fluid flow rate in heat exchanger Qa: air flow Pfs: sensible cooling capacity Tad: discharge air dry temperature Taw: discharge air wet temperature

SWC-20-V-ECM

		TAI DB24°C-WB17.4°C						TAI DB27°C-WB19°C						TAI DB27°C-WB19.5°C						TAI DB28°C-WB21°C					
Twi	qa	Pf	Pfs	Tad	Taw	dPw	Qw	Pf	Pfs	Tad	Taw	dPw	Qw	Pf	Pfs	Tad	Taw	dPw	Qw	Pf	Pfs	Tad	Taw	dPw	Qw
°C	m3/h	kW	kW	°C	°C	kPa	l/s	kW	kW	°C	°C	kPa	l/s	kW	kW	°C	°C	kPa	l/s	kW	kW	°C	°C	kPa	l/s
5	980	5.13	3.53	12.5	11	19.7	0.244	6.19	4.18	13.2	11.5	27.2	0.295	6.55	4.19	13.2	11.7	30	0.312	7.65	4.41	13.5	12.2	39.3	0.365
	760	4.18	2.86	11.9	10.7	13.9	0.199	5.04	3.39	12.6	11.1	19.1	0.24	5.33	3.39	12.6	11.3	21	0.254	6.21	3.57	12.8	11.7	27.4	0.296
	600	3.46	2.36	11.4	10.3	10	0.165	4.16	2.79	12	10.7	13.8	0.198	4.39	2.79	12	10.8	15.1	0.209	5.12	2.94	12.2	11.3	19.7	0.244
7	980	4.1	3.07	14	12.4	13.2	0.196	5.19	3.73	14.7	12.9	19.8	0.247	5.55	3.74	14.7	13	22.3	0.265	6.66	3.96	14.9	13.5	30.5	0.318
	760	3.36	2.49	13.5	12.1	9.4	0.16	4.23	3.03	14.1	12.5	14	0.202	4.53	3.03	14.1	12.7	15.7	0.216	5.42	3.21	14.3	13.1	21.4	0.258
	600	2.78	2.06	13	11.8	6.84	0.133	3.5	2.49	13.6	12.2	10.1	0.167	3.74	2.5	13.6	12.3	11.3	0.178	4.47	2.64	13.8	12.7	15.4	0.213
9	980	2.97	2.6	15.5	13.9	7.53	0.142	4.1	3.28	16.2	14.3	13	0.195	4.47	3.28	16.2	14.4	15.1	0.213	5.59	3.51	16.4	14.9	22.2	0.267
	760	2.44	2.11	15.1	13.6	5.4	0.117	3.35	2.66	15.7	14	9.24	0.16	3.65	2.66	15.7	14.1	10.7	0.174	4.56	2.85	15.9	14.5	15.7	0.218
	600	2.04	1.74	14.7	13.4	3.97	0.0972	2.78	2.19	15.2	13.7	6.7	0.133	3.03	2.19	15.2	13.8	7.77	0.144	3.77	2.35	15.4	14.2	11.3	0.18

Pf: total cooling capacity Tal: in flow air temperature dpw: pressure drop standard coil Twi: entering water temperature, water temperature arise 5°C.

Qw: fluid flow rate in heat exchanger Qa: air flow Pfs: sensible cooling capacity Tad: discharge air dry temperature Taw: discharge air wet temperature

SWC-24-V-ECM

		TAI DB24°C-WB17.4°C						TAI DB27°C-WB19°C						TAI DB27°C-WB19.5°C						TAI DB28°C-WB21°C					
Twi	qa	Pf	Pfs	Tad	Taw	dPw	Qw	Pf	Pfs	Tad	Taw	dPw	Qw	Pf	Pfs	Tad	Taw	dPw	Qw	Pf	Pfs	Tad	Taw	dPw	Qw
°C	m3/h	kW	kW	°C	°C	kPa	l/s	kW	kW	°C	°C	kPa	l/s	kW	kW	°C	°C	kPa	l/s	kW	kW	°C	°C	kPa	l/s
5	1240	6.17	4.27	13	11.4	27.1	0.294	7.47	5.06	13.8	11.9	37.7	0.356	7.91	5.07	13.8	12.1	41.6	0.377	9.24	5.33	14.1	12.7	54.6	0.44
	1080	5.54	3.82	12.7	11.2	22.5	0.264	6.69	4.53	13.4	11.7	31.2	0.319	7.09	4.53	13.5	11.9	34.4	0.338	8.28	4.77	13.7	12.4	45.1	0.395
	760	4.18	2.86	11.9	10.7	13.9	0.199	5.04	3.39	12.6	11.1	19.1	0.24	5.33	3.39	12.6	11.3	21	0.254	6.21	3.57	12.8	11.7	27.4	0.296
7	1240	4.93	3.71	14.4	12.7	18.1	0.235	6.25	4.52	15.2	13.2	27.2	0.298	6.69	4.52	15.2	13.4	30.7	0.319	8.04	4.79	15.5	13.9	42.2	0.383
	1080	4.43	3.32	14.2	12.5	15.1	0.211	5.61	4.04	14.9	13	22.6	0.267	6	4.05	14.9	13.2	25.5	0.286	7.21	4.29	15.2	13.7	34.9	0.344
	760	3.36	2.49	13.5	12.1	9.4	0.16	4.23	3.03	14.1	12.5	14	0.202	4.53	3.03	14.1	12.7	15.7	0.216	5.42	3.21	14.3	13.1	21.4	0.258
9	1240	3.55	3.14	15.9	14.1	10.2	0.169	4.91	3.96	16.7	14.5	17.8	0.234	5.36	3.97	16.7	14.7	20.7	0.256	6.73	4.24	16.9	15.2	30.7	0.321
	1080	3.2	2.81	15.7	14	8.54	0.153	4.42	3.55	16.4	14.4	14.8	0.211	4.82	3.55	16.4	14.5	17.2	0.23	6.04	3.8	16.6	15	25.4	0.288
	760	2.44	2.11	15.1	13.6	5.4	0.117	3.35	2.66	15.7	14	9.24	0.16	3.65	2.66	15.7	14.1	10.7	0.174	4.56	2.85	15.9	14.5	15.7	0.218

Pf: total cooling capacity Tal: in flow air temperature dpw: pressure drop standard coil Twi: entering water temperature, water temperature arise 5°C.

Qw: fluid flow rate in heat exchanger Qa: air flow Pfs: sensible cooling capacity Tad: discharge air dry temperature Taw: discharge air wet temperature

B.3.2. Heating Capacity Table – 2-pipe systems

SWC-04-V-ECM

			TAI 18°C				TAI 20°C				TAI 22°C				TAI 24°C			
Tw _i	Tw _o	q _a	P _f	T _{ad}	Q _w	dP _w	P _f	T _{ad}	Q _w	dP _w	P _f	T _{ad}	Q _w	dP _w	P _f	T _{ad}	Q _w	dP _w
°C	°C	m ³ /h	kW	°C	l/s	kPa	kW	°C	l/s	kPa	kW	°C	l/s	kPa	kW	°C	l/s	kPa
45	40	370	1.47	30.4	0.0701	10.02	1.34	31.4	0.064	8.64	1.21	32.4	0.0579	7.26	1.08	33.4	0.0518	5.88
		290	1.22	31.2	0.0579	7.2	1.11	32.1	0.0529	6.21	1	33	0.0479	5.22	0.89	33.9	0.0429	4.23
		220	0.966	32.1	0.0462	4.87	0.882	32.9	0.0422	4.2	0.798	33.7	0.0382	3.53	0.714	34.5	0.0342	2.86
60	40	370	1.58	31.5	0.0378	3.48	1.45	32.4	0.0347	3	1.32	33.3	0.0316	2.52	1.19	34.2	0.0285	2.04
		290	1.3	32.2	0.0314	2.47	1.2	33.1	0.0288	2.15	1.1	34	0.0262	1.83	1	34.9	0.0236	1.51
		220	1.8344	33.1	0.025	1.69	0.961	34	0.023	1.47	0.876	34.9	0.021	1.25	0.791	35.8	0.019	1.03
70	60	370	2.83	42	0.0676	8.74	2.7	43	0.0644	8.05	2.57	44	0.0612	7.36	2.44	45	0.058	6.67
		290	2.34	43.3	0.056	6.26	2.23	44.3	0.0533	5.77	2.12	45.3	0.0506	5.28	2.01	46.3	0.0479	4.79
		220	1.87	45.1	0.0445	4.21	1.78	46	0.0424	3.88	1.69	46.9	0.0403	3.55	1.6	47.8	0.0382	3.22
P _f : total heating capacity dp _w : pressure drop standard coil Q _w : fluid flow rate in heat exchanger T _{ad} : discharge air dry temperature																		
T _{ai} : in flow air temperature Tw _i : in flow fluid temperature Tw _o : out flow fluid temperature Q _a : air flow																		

SWC-06-V-ECM

			TAI 18°C				TAI 20°C				TAI 22°C				TAI 24°C			
TwI	Two	qa	Pf	Tad	Qw	dPw	Pf	Tad	Qw	dPw	Pf	Tad	Qw	dPw	Pf	Tad	Qw	dPw
°C	°C	m3/h	kW	°C	l/s	kPa	kW	°C	l/s	kPa	kW	°C	l/s	kPa	kW	°C	l/s	kPa
45	40	500	2.41	33.1	0.1148	11.81	2.2	33.9	0.105	10.2	1.99	34.7	0.0952	8.59	1.78	35.5	0.0854	6.98
		370	1.91	34.1	0.091	7.87	1.74	34.8	0.0831	6.79	1.57	35.5	0.0752	5.71	1.4	36.2	0.0673	4.63
		290	1.55	34.8	0.0746	5.57	1.42	35.5	0.0681	4.81	1.29	36.2	0.0616	4.05	1.16	36.9	0.0551	3.29
60	40	500	2.62	34.4	0.0624	4.05	2.4	35.2	0.0573	3.53	2.18	36	0.0522	3.01	1.96	36.8	0.0471	2.49
		370	2.07	35.5	0.0495	2.71	1.9	36.2	0.0455	2.37	1.73	36.9	0.0415	2.03	1.56	37.6	0.0375	1.69
		290	1.69	36.3	0.0407	1.95	1.56	37	0.0374	1.7	1.43	37.7	0.0341	1.45	1.3	38.4	0.0308	1.2
70	60	500	4.66	47.3	0.111	10.35	4.44	48.1	0.106	9.53	4.22	48.9	0.101	8.71	4	49.7	0.096	7.89
		370	3.67	49	0.0877	6.84	3.5	49.8	0.0836	6.3	3.33	50.6	0.0795	5.76	3.16	51.4	0.0754	5.22
		290	3.01	50.6	0.0719	4.83	2.87	51.3	0.0685	4.45	2.73	52	0.0651	4.07	2.59	52.7	0.0617	3.69
Pf: total heating capacity dpw: pressure drop standard coil Qw: fluid flow rate in heat exchanger Tad: discharge air dry temperature																		
Tai: in flow air temperature Twi: in flow fluid temperature Two: out flow fluid temperature Qa: air flow																		

SWC-12-V-ECM

			TAI 18°C				TAI 20°C				TAI 22°C				TAI 24°C			
TwI	Two	qa	Pf	Tad	Qw	dPw	Pf	Tad	Qw	dPw	Pf	Tad	Qw	dPw	Pf	Tad	Qw	dPw
°C	°C	m3/h	kW	°C	l/s	kPa	kW	°C	l/s	kPa	kW	°C	l/s	kPa	kW	°C	l/s	kPa
45	40	500	2.83	35.8	0.136	9.61	2.59	36.4	0.124	8.29	2.35	37	0.112	6.97	2.11	37.6	0.1	5.65
		370	2.22	36.8	0.1063	5.37	2.03	37.3	0.0971	5.42	1.84	37.8	0.0879	5.47	1.65	38.3	0.0787	5.52
		290	1.81	37.6	0.0863	4.38	1.65	38	0.0789	3.79	1.49	38.4	0.0715	3.2	1.33	38.8	0.0641	2.61
60	40	500	3.1	37.6	0.0742	3.33	2.85	38.1	0.0682	2.91	2.6	38.6	0.0622	2.49	2.35	39.1	0.0562	2.07
		370	2.43	38.6	0.0585	2.21	2.24	39.1	0.0537	1.93	2.05	39.6	0.0489	1.65	1.86	40.1	0.0441	1.37
		290	1.99	39.4	0.0474	1.57	1.83	39.9	0.0437	1.37	1.67	40.4	0.04	1.17	1.51	40.9	0.0363	0.97
70	60	500	5.49	52.5	0.131	8.37	5.23	53.1	0.125	7.71	4.97	53.7	0.119	7.05	4.71	54.3	0.113	6.39
		370	4.29	54.2	0.1024	5.45	4.09	54.8	0.0976	5.02	3.89	55.4	0.0928	4.59	3.69	56	0.088	4.16
		290	3.48	55.7	0.0832	3.8	3.32	56.2	0.0793	3.5	3.16	56.7	0.0754	3.2				
Pf: total heating capacity dpw: pressure drop standard coil Qw: fluid flow rate in heat exchanger Tad: discharge air dry temperature																		
Tai: in flow air temperature Twi: in flow fluid temperature Two: out flow fluid temperature Qa: air flow																		

SWC-15-V-ECM

			TAI 18°C				TAI 20°C				TAI 22°C				TAI 24°C			
Twi	Two	qa	Pf	Tad	Qw	dPw	Pf	Tad	Qw	dPw	Pf	Tad	Qw	dPw	Pf	Tad	Qw	dPw
°C	°C	m3/h	kW	°C	l/s	kPa	kW	°C	l/s	kPa	kW	°C	l/s	kPa	kW	°C	l/s	kPa
45	40	645	3.5	35.1	0.166	13.82	3.19	35.7	0.152	11.9	2.88	36.3	0.138	9.98	2.57	36.9	0.124	8.06
		445	2.59	36.3	0.124	8.14	2.36	36.8	0.113	7.03	2.13	37.3	0.102	5.92	1.9	37.8	0.091	4.81
		370	2.22	36.8	0.1063	6.27	2.03	37.3	0.0971	5.42	1.84	37.8	0.0879	4.57	1.65	38.3	0.0787	3.72
60	40	645	3.8	36.6	0.0907	4.74	3.49	37.2	0.0834	4.13	3.18	37.8	0.0761	3.52	2.87	38.4	0.0688	2.91
		445	2.83	38	0.0675	2.84	2.6	38.5	0.0621	2.48	2.37	39	0.0567	2.12	2.14	39.5	0.0513	1.76
		370	2.43	38.6	0.0583	2.21	2.24	39.1	0.0536	1.93	2.05	39.6	0.0489	1.65	1.86	40.1	0.0442	1.37
70	60	645	6.75	51.1	0.16	12.1	6.43	51.7	0.153	11.1	6.11	52.3	0.146	10.1	5.79	52.9	0.139	9.1
		445	4.98	53.2	0.118	7.09	4.75	53.8	0.113	6.53	4.52	54.4	0.108	5.97	4.29	55	0.103	5.41
		370	4.29	54.2	0.1024	5.45	4.09	54.8	0.0976	5.02	3.89	55.4	0.0928	4.59	3.69	56	0.088	4.16
Pf: total heating capacity dpw: pressure drop standard coil Qw: fluid flow rate in heat exchanger Tad: discharge air dry temperature																		
Tai: in flow air temperature Twi: in flow fluid temperature Two: out flow fluid temperature Qa: air flow																		

SWC-18-V-ECM

			TAI 18°C				TAI 20°C				TAI 22°C				TAI 24°C			
Twi	Two	qa	Pf	Tad	Qw	dPw	Pf	Tad	Qw	dPw	Pf	Tad	Qw	dPw	Pf	Tad	Qw	dPw
°C	°C	m3/h	kW	°C	l/s	kPa	kW	°C	l/s	kPa	kW	°C	l/s	kPa	kW	°C	l/s	kPa
45	40	876	4.78	35.2	0.229	18.7	4.37	35.8	0.209	16.1	3.96	36.4	0.189	13.5	3.55	37	0.169	10.9
		740	4.17	35.7	0.199	14.7	3.81	36.3	0.182	12.7	3.45	36.9	0.165	10.7	3.09	37.5	0.148	8.7
		570	3.36	36.6	0.161	10.06	3.07	37.1	0.147	8.69	2.78	37.6	0.133	7.32	2.49	38.1	0.119	5.95
60	40	876	5.22	36.8	0.125	6.44	4.8	37.4	0.115	5.62	4.38	38	0.105	4.8	3.96	38.6	0.095	3.98
		740	4.57	37.5	0.1084	5.1	4.2	38	0.1	4.45	3.83	38.5	0.0916	3.8	3.46	39	0.0832	3.15
		570	3.68	38.5	0.0883	3.54	3.39	38.9	0.0812	3.09	3.1	39.3	0.0741	2.64	2.81	39.7	0.067	2.19
70	60	876	9.24	51.2	0.22	16.3	8.81	51.9	0.21	15	8.38	52.6	0.2	13.7	7.95	53.3	0.19	12.4
		740	8.06	52.3	0.192	12.8	7.68	52.9	0.183	11.8	7.3	53.5	0.174	10.8	6.92	54.1	0.165	9.8
		570	6.49	53.9	0.156	8.75	6.18	54.4	0.148	8.06	5.87	54.9	0.14	7.37	5.56	55.4	0.132	6.68
Pf: total heating capacity dpw: pressure drop standard coil Qw: fluid flow rate in heat exchanger Tad: discharge air dry temperature																		
Tai: in flow air temperature Twi: in flow fluid temperature Two: out flow fluid temperature Qa: air flow																		

SWC-20-V-ECM

			TAI 18°C				TAI 20°C				TAI 22°C				TAI 24°C			
Twi	Two	qa	Pf	Tad	Qw	dPw	Pf	Tad	Qw	dPw	Pf	Tad	Qw	dPw	Pf	Tad	Qw	dPw
°C	°C	m3/h	kW	°C	l/s	kPa	kW	°C	l/s	kPa	kW	°C	l/s	kPa	kW	°C	l/s	kPa
45	40	980	5.58	35.9	0.267	18.5	5.1	36.5	0.244	16	4.62	37.1	0.221	13.5	4.14	37.7	0.198	11
		760	4.52	36.7	0.217	12.86	4.13	37.2	0.198	11.1	3.74	37.7	0.179	9.34	3.35	38.2	0.16	7.58
		600	3.71	37.4	0.177	9.1	3.39	37.9	0.162	7.87	3.07	38.4	0.147	6.64	2.75	38.9	0.132	5.41
60	40	980	6.13	37.6	0.147	6.47	5.64	38.2	0.135	5.65	5.15	38.8	0.123	4.83	4.66	39.4	0.111	4.01
		760	4.98	38.6	0.12	4.52	4.58	39.1	0.11	3.95	4.18	39.6	0.1	3.38	3.78	40.1	0.09	2.81
		600	4.09	39.4	0.0981	3.23	3.77	39.9	0.0903	2.83	3.45	40.4	0.0825	2.43	3.13	40.9	0.0747	2.03
70	60	980	10.83	52.6	0.257	22.1	10.3	53.2	0.245	17.9	9.77	53.8	0.233	13.7	9.24	54.4	0.221	9.5
		760	8.72	54.2	0.207	11.19	8.31	54.7	0.198	10.3	7.9	55.2	0.189	9.41	7.49	55.7	0.18	8.52
		600	7.17	55.5	0.171	7.89	6.83	56	0.163	7.28	6.49	56.5	0.155	6.67	6.15	57	0.147	6.06
Pf: total heating capacity dpw: pressure drop standard coil Qw: fluid flow rate in heat exchanger Tad: discharge air dry temperature																		
Tai: in flow air temperature Twi: in flow fluid temperature Two: out flow fluid temperature Qa: air flow																		

SWC-24-V-ECM

			TAI 18°C				TAI 20°C				TAI 22°C				TAI 24°C			
Twi	Two	qa	Pf	Tad	Qw	dPw	Pf	Tad	Qw	dPw	Pf	Tad	Qw	dPw	Pf	Tad	Qw	dPw
°C	°C	m3/h	kW	°C	l/s	kPa	kW	°C	l/s	kPa	kW	°C	l/s	kPa	kW	°C	l/s	kPa
45	40	1240	6.78	35.2	0.324	26.1	6.19	35.8	0.296	22.5	5.6	36.4	0.268	18.9	5.01	37	0.24	15.3
		1080	6.05	35.6	0.29	21.5	5.53	36.2	0.265	18.5	5.01	36.8	0.24	15.5	4.49	37.4	0.215	12.5
		760	4.52	36.7	0.217	12.86	4.13	37.2	0.198	11.1	3.74	37.7	0.179	9.34	3.35	38.2	0.16	7.58
60	40	1240	7.4	36.8	0.177	8.99	6.81	37.4	0.163	7.84	6.22	38	0.149	6.69	5.63	38.6	0.135	5.54
		1080	6.63	37.3	0.159	7.42	6.1	37.9	0.146	6.48	5.57	38.5	0.133	5.54	5.04	39.1	0.12	4.6
		760	4.98	38.6	0.12	4.52	4.58	39.1	0.11	3.95	4.18	39.6	0.1	3.38	3.78	40.1	0.09	2.81
70	60	1240	13.2	51.3	0.313	22.8	12.5	51.9	0.298	21	11.8	52.5	0.283	19.2	11.1	53.1	0.268	17.4
		1080	11.6	52.1	0.279	18.7	11.1	52.7	0.266	17.2	10.6	53.3	0.253	15.7	10.1	53.9	0.24	14.2
		760	8.72	54.2	0.207	11.19	8.31	54.7	0.198	10.3	7.9	55.2	0.189	9.41	7.49	55.7	0.18	8.52
Pf: total heating capacity dpw: pressure drop standard coil Qw: fluid flow rate in heat exchanger Tad: discharge air dry temperature																		
Tai: in flow air temperature Twi: in flow fluid temperature Two: out flow fluid temperature Qa: air flow																		

B.4. Dimensional Drawings

Dimensional drawing for SWC-04/06/12/15/18-ECM

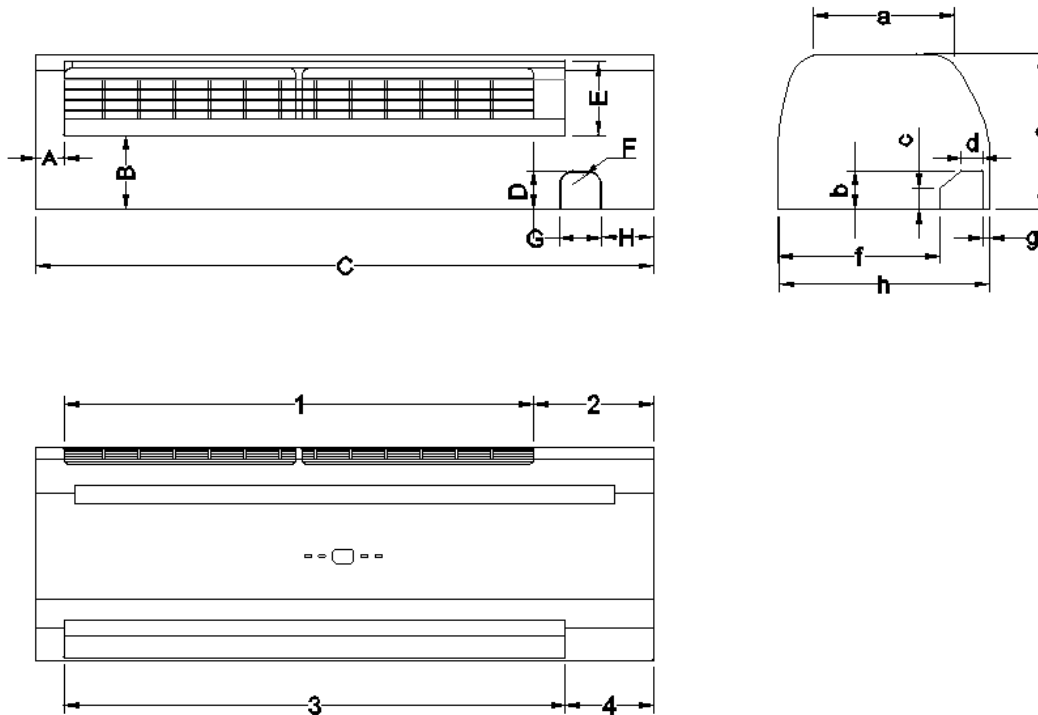

Model	Unit Dimensions (mm)							
	A	B	C	D	E	F	G	H
SWC-04/06/12/15/18	40	105	875	55	105	R20	60	74

Model	Unit Dimensions (mm)							
	a	b	c	d	e	f	g	h
SWC-04/06/12/15/18	200	55	30	30	220	229	10	300

Model	Unit Dimensions (mm)			
	1	2	3	4
SWC-04/06/12/15/18	665	170	710	125

(All dimensions shown in mm)

Dimensional drawing for SWC-20/24-ECM

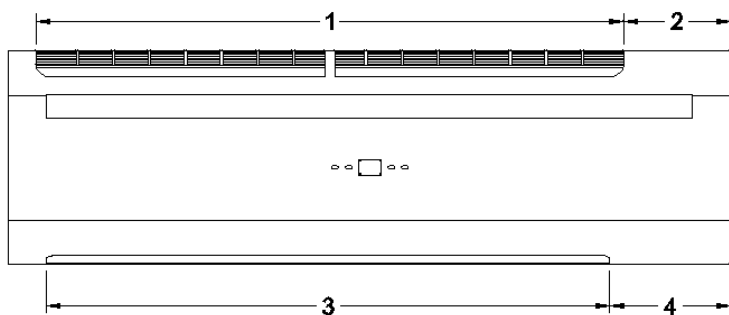
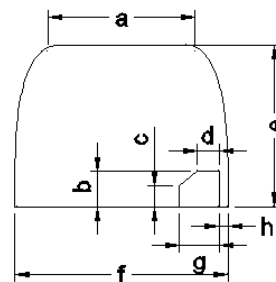
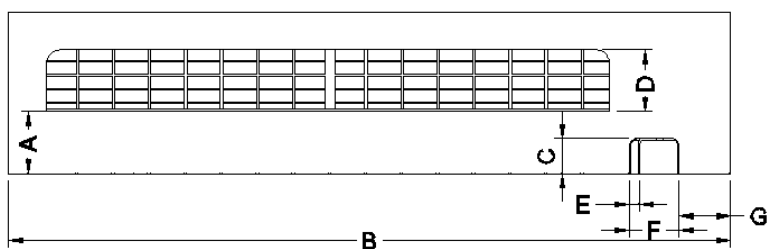

Model	Unit Dimensions (mm)						
	A	B	C	D	E	F	G
SWC-20/24	90	1050	51	90	15	73	74

Model	Unit Dimensions (mm)							
	a	b	c	d	e	f	g	h
SWC-20/24	215	52	30	32	235	310	58	13

Model	Unit Dimensions (mm)			
	1	2	3	4
SWC-20/24	855	155	820	175

(All dimensions shown in mm)

B.5. Valve Information

B.5.1. 2-Way Valve Body

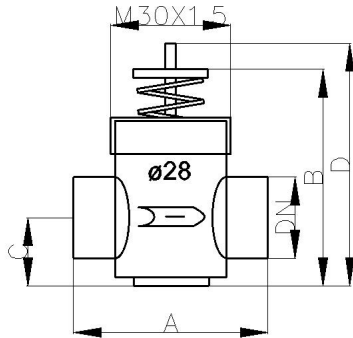

Valve Dimensions (mm)				
DN	A	B	C	D
D15 (G1/2")	52	47	19.5	63

Differential Pressure Chart (2-Way Valve)

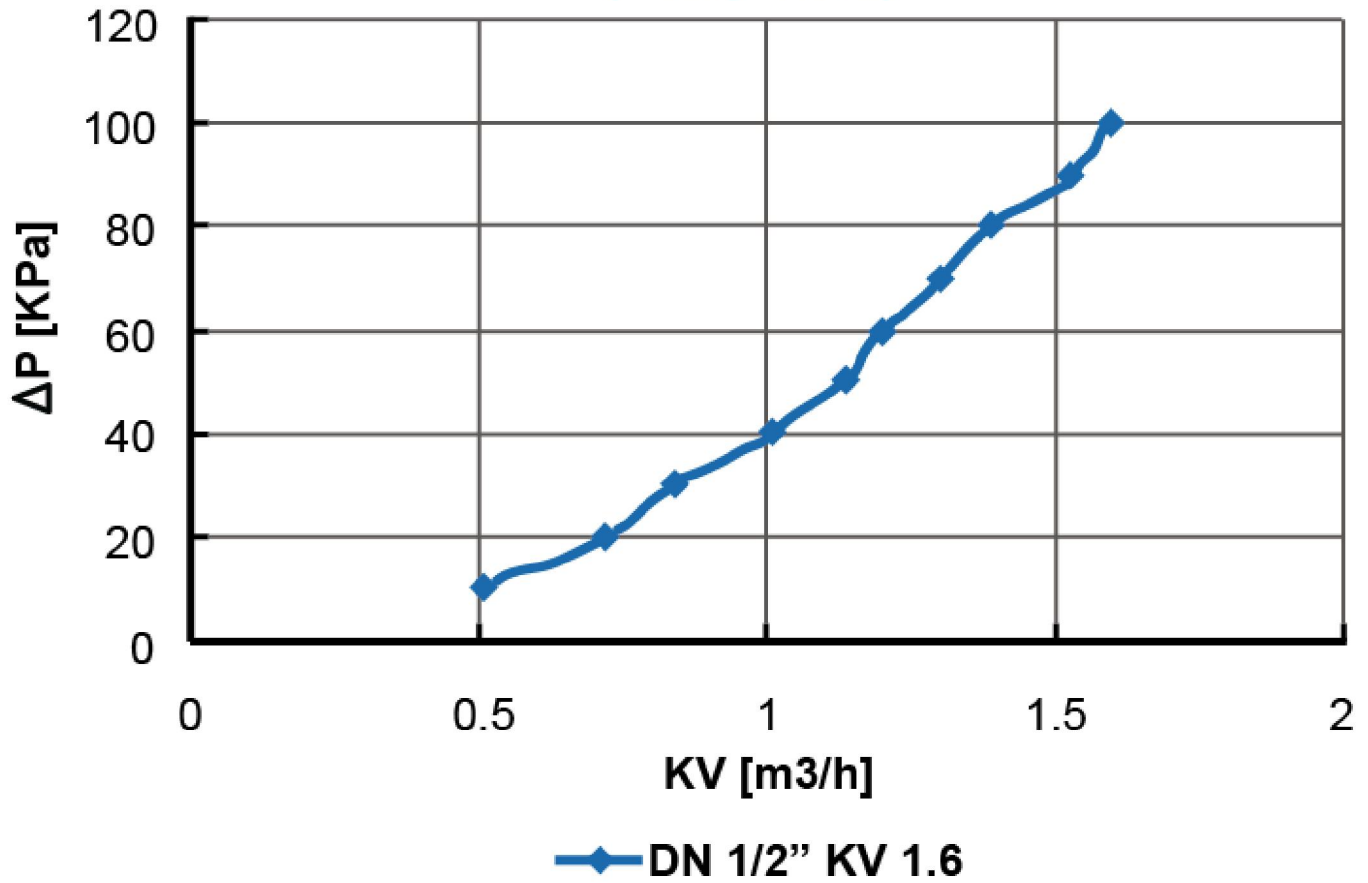

C. Service and Installation

C.1. Installation of High-Wall Unit

C.1.1. Selecting a Location

Select the location for the High-wall unit with the following considerations:

1. The front of the air inlet and outlet should be free from any obstructions. The air should flow freely.
2. The wall where the unit is to be mounted should be stiff enough not to resonate and produce noise.
3. The location should allow easy access to install the connecting water pipes, and be where drainage can be easily obtained.
4. Ensure the clearance on every side of the fan coil unit conforms to the following drawing.
5. From the floor the height should be more than eye level.
6. Avoid installing the unit in direct sunlight.

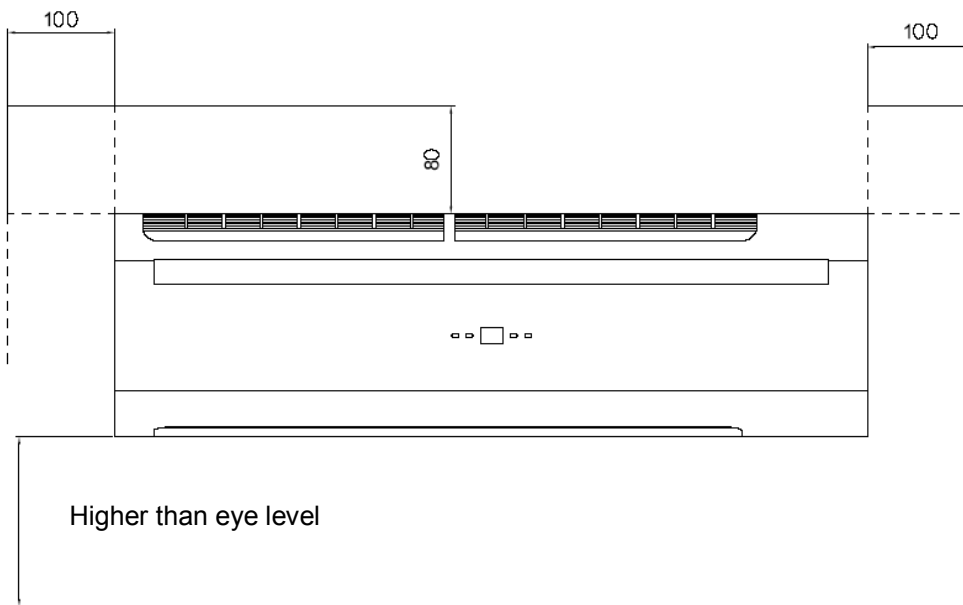

* Required clearance for maintenance and servicing is as shown above.

** All dimensions shown in mm.

7. The signal receiver on the unit must be kept away from any high frequency emission source.
8. Keep the unit away from fluorescent lamps, which may affect the control system.
9. To avoid electromagnetic control system interference, ensure control wires are installed separately from 220-240 VAC power wires.
10. Where electromagnetic waves exist use shielded sensor cables.
11. Install a noise filter if any harmful noise exists in the power supply.

C.1.2. Mounting Plate Dimensions

SWC-04/06/12/15/18 –ECM

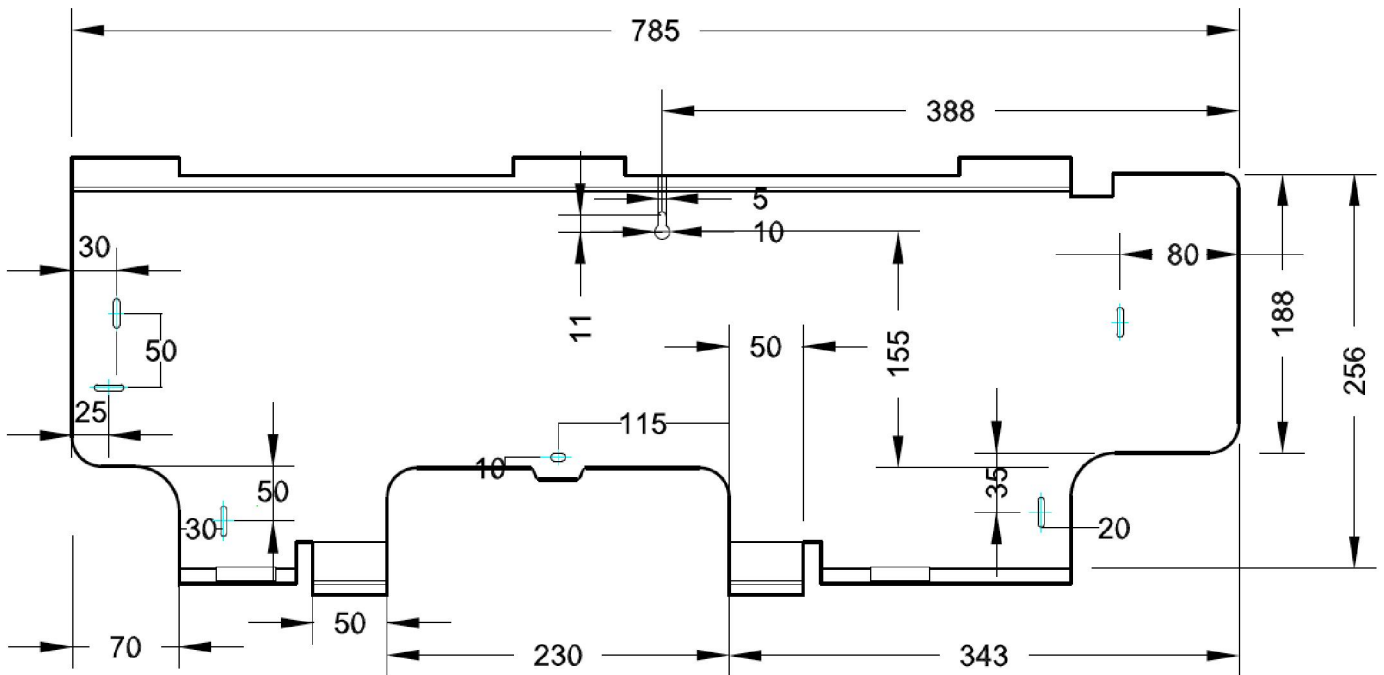

SWC-20/24 –ECM

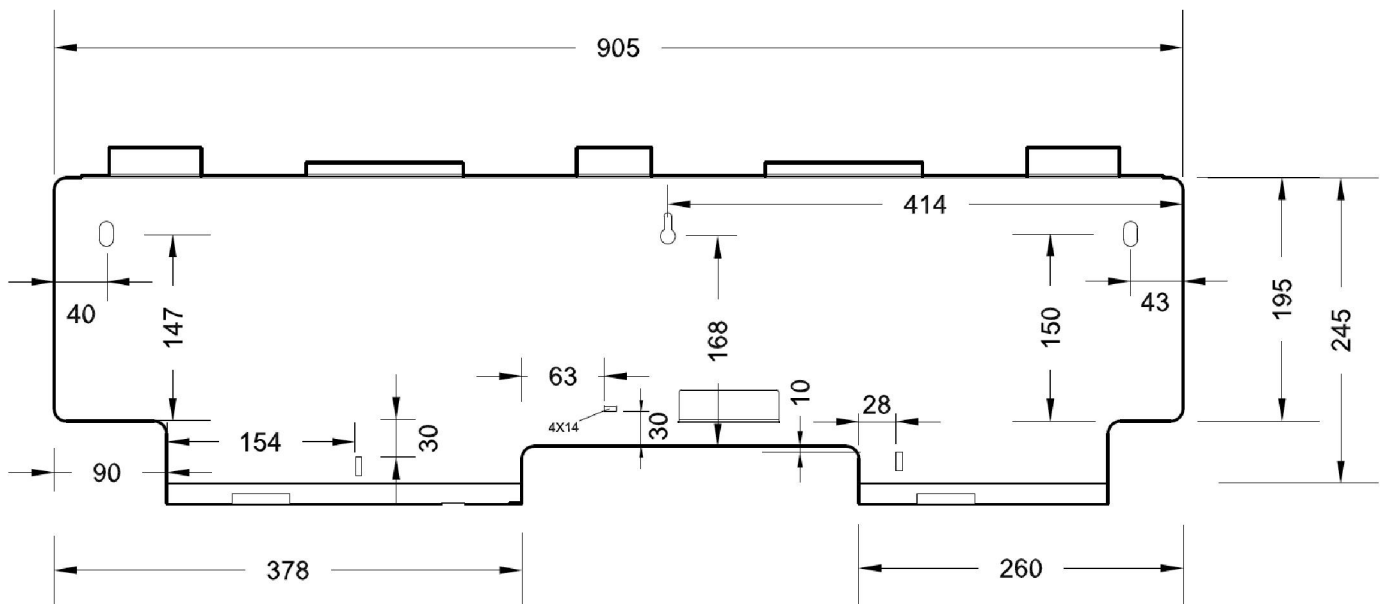

(All dimensions shown in mm)

C.1.3. Installing the Mounting Plate

1. Select the structural position (e.g. a pillar or lintel) on the wall.
2. Then temporarily fasten the mounting plate on the wall with a steel nail.

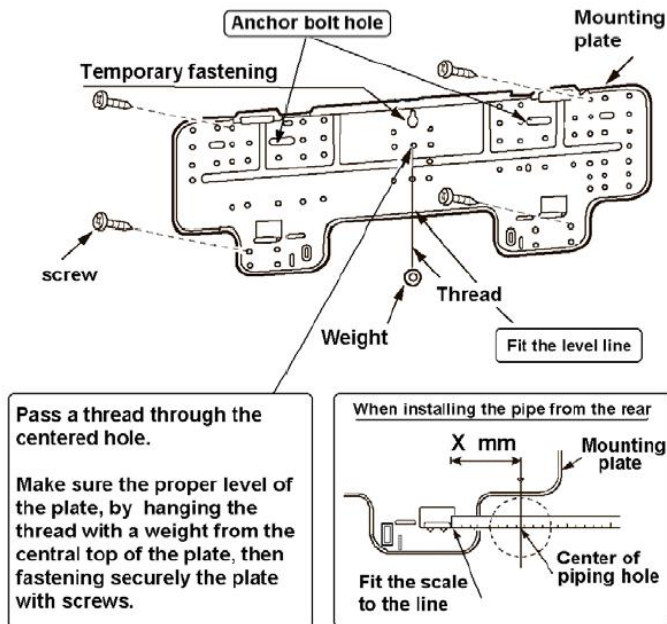

3. Mount the mounting plate horizontally as shown in the above figure or by means of gradiometer. Fail to follow this may cause indoor water dripping and abnormal noise.
4. Fix the mounting plate by means of expansion screws or tapping screws.

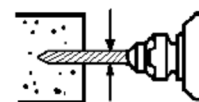

Drill a hole on the wall

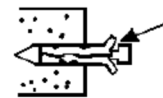

Anchor plastic clip



Expansion screw

C.1.4. Drilling the Condensate Drainage Hole

1. Ensure that the hole for condensate drainage is correctly positioned. The height should be lower than the below edge of the indoor unit.
2. Drill a 65mm diameter hole with a descending slope.
3. Seal it off with putty after installation.

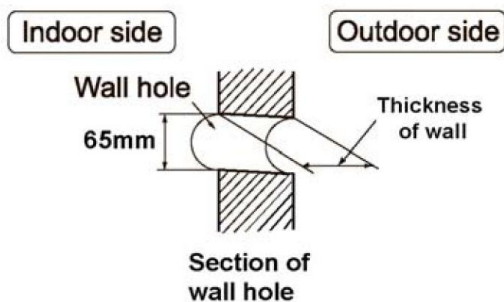

C.1.5. Installing the Hydronic Unit

1. Pass the piping through the hole in the wall and hook the indoor unit on the mounting plate at the upper hooks.
2. Move the body from side to verify if it is securely fixed.
3. While pushing the unit onto the wall from the underside, hook it up on the mounting plate at the lower part.
4. Make sure the units are firmly hooked up on the mounting plate.

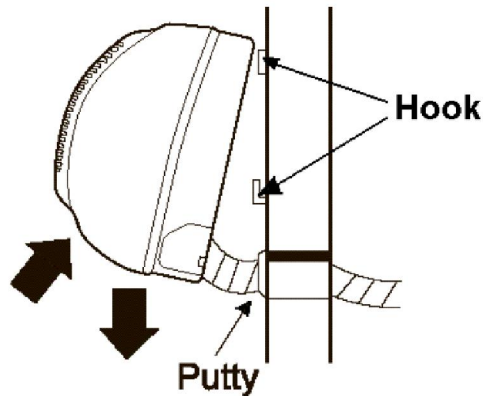

C.1.6. Drainage Piping Works

1. Install the drain hose so that it slopes downward slightly for free drainage. Avoid installing it as shown in the below illustration marked with "X".

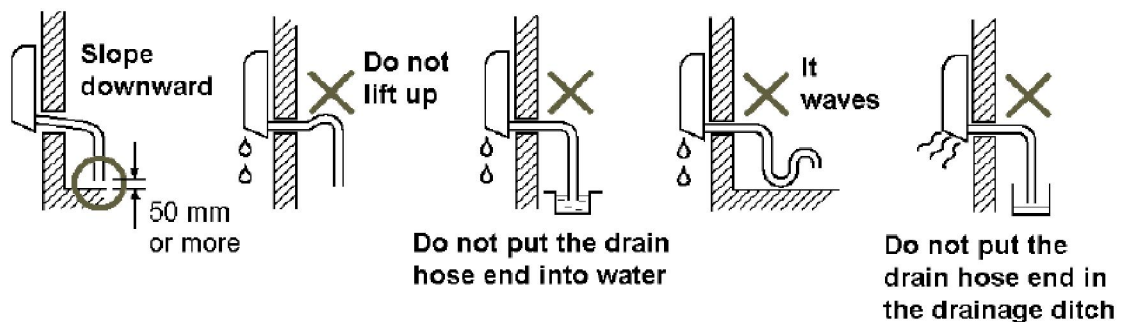

2. Put water in the drain pan and make sure that the water is drained outdoors.
3. If the flexible drain hose provided in the indoor unit is not long enough, please extend it by joining it to an extension hose (not provided). Be sure to insulate the connecting part of the extension drain hose with a shield pipe as shown.

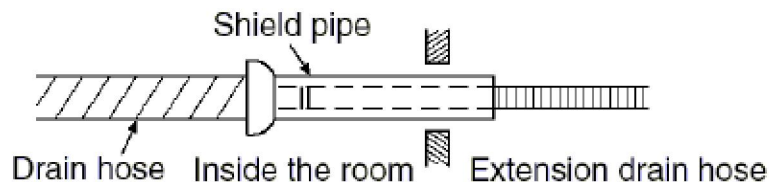

4. In case that the attached (if it is attached) drain hose passes through an indoor area, insulate it with heat insulation material.

C.2. Unit Maintenances and Preparations

C.2.1. Opening and Closing Of Lift-Up Grille Cover



Open the lift-up gridded cover by lifting from the bottom position indicated by the arrow



Close the lift-up gridded cover by pressing the two sides down at the position of the arrow.

C.2.2. Removing Front Cover Assembly

1. Set the horizontal louver to horizontal position.
2. Remove the screw caps below the louver, and then remove the mounting screws.
3. Open the lift-up grille cover by grasping the panel at both sides as shown above.
4. Remove the remaining screws located at the centers.
5. Grasp the lower part of the front cover and pull the entire assembly out and up towards you.

C.2.3. Air Purging

1. After connecting the water inlet and outlet pipes to the main supply lines turn on the main breaker and operate the unit in COOLING mode.
2. Open the water inlet valve and flood the coil.
3. Check all connections for water leakage, if no leak is found open the purging valve by using hand and support the unit with an open end wrench. Then purge the air trapped inside the coil. When performing this activity, take care not to touch the electrical parts.
4. Close the purging valve when no bubbles appear.
5. Open the water outlet valve.

C.2.4. Wiring Connections

1. Unit components are wired to the terminal block of indoor unit. Wirings can be accessed from the terminal block inside the control box.

C.3. Pipe Connections with Valve

Pre-assembly

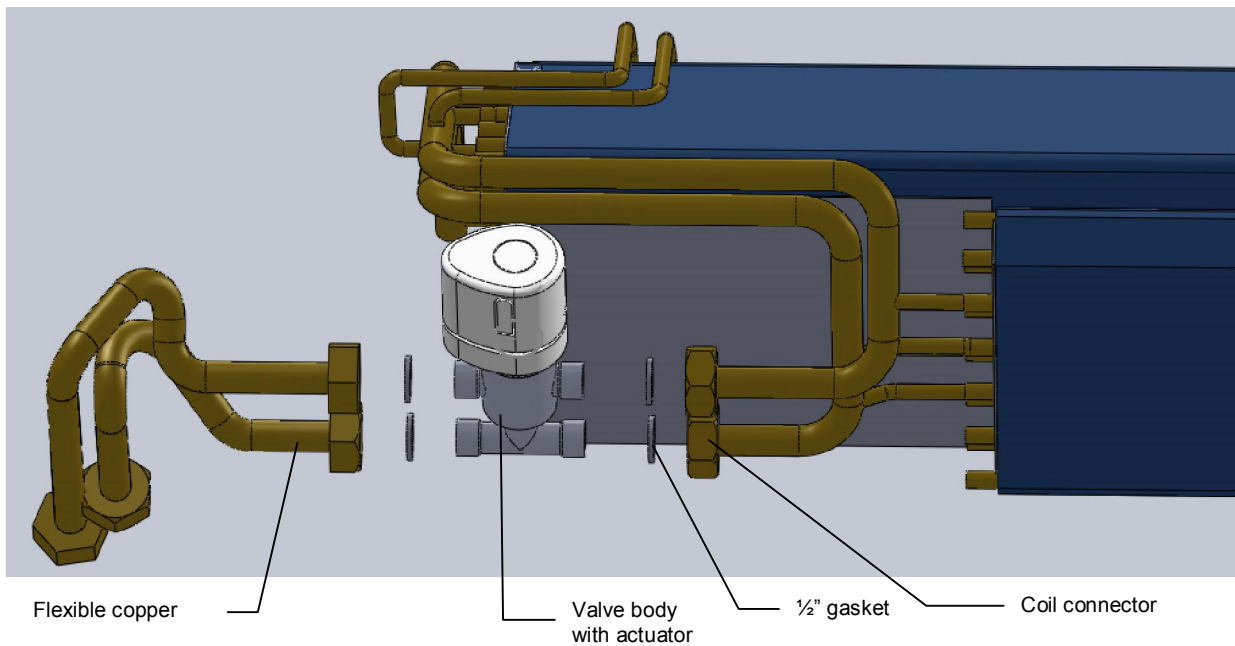

Complete Assembly

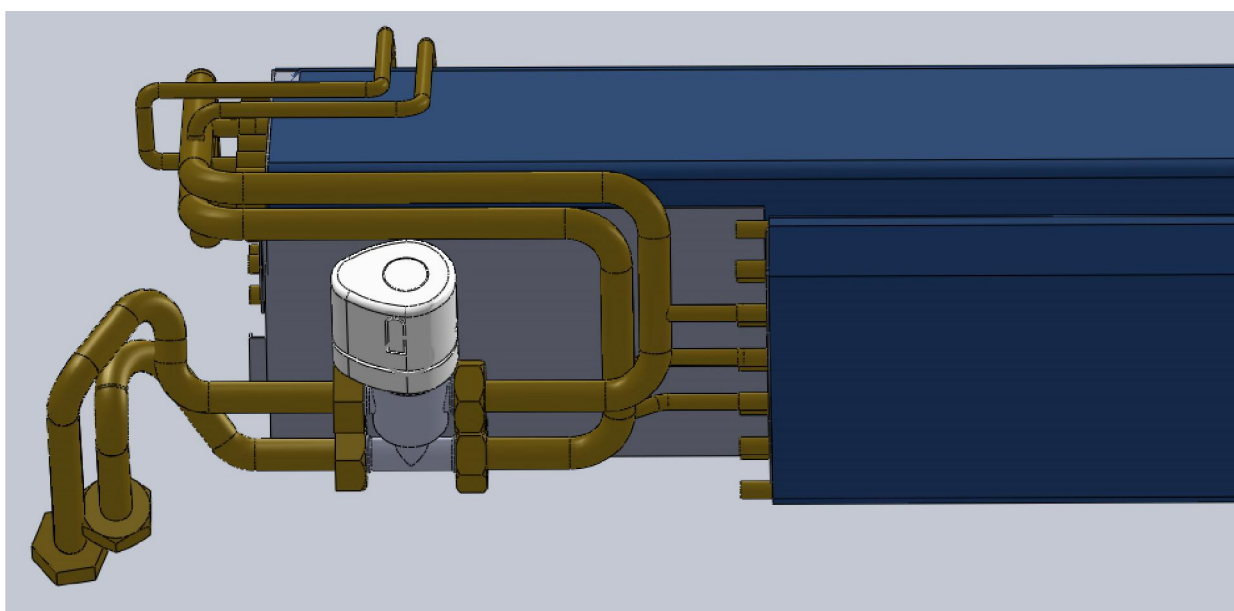

D. Control Specifications

D.1. SK-NCSWC-001 Complete function FCU Controller

Used in all High-wall [V/P] ~S unit configurations.

D.1.1. Abbreviations

Ts = Setting temperature

Tr = Room air temperature

Ti1 = Chilled water coil temperature

Ti2 = Hot water coil temperature

AUX1 = Hot water free contact

AUX2 = Chilled water free contact

MTV1 = Chilled Motorized valve

MTV2 = Hot Motorized valve

D.1.2. Definition of Input/Output

I/O		Code	2-Pipe	4-Pipe
Analogue Input	Return air sensor	AI1	Return air temperature (Tr)	
	2-pipe coil circuit sensor	AI2	Chilled / hot water coil circuit (Ti1)	Chilled water coil circuit (Ti1)
	Hot water sensor	AI3	N/A	Hot water coil circuit (Ti2)
Input	LED display / IR receiver	X-DIS1	Digital communication port to LED display / IR receiver board.	
	Wired wall pad	TTL1	Digital communication port to wired wall pad board.	
Digital input	Occupancy contact	On/Off	Window contacts: for remote ON/OFF (when DIPB SW1 = 1). Economy contacts: for remote activation of economy mode (when DIPB SW1 = 0).	
	Electrical heater safety switch	EH	Voltage-free (NC). The contact is closed before the EH is turned on.	
Power input	Phase	L1	Power supply to the PCB and all the loads connected to the voltage outputs. Max length: 5 m.	
	Neutral	N1	Power supply to the PCB and all the loads connected to the voltage outputs. Max length: 5 m.	
	Earth	PE1	Power supply to the PCB and all the loads connected to the voltage outputs. Max length: 5 m.	
Voltage output	Fan	CN4	Fan driver	
	Valve 1	MTV1	2-pipe coil circuit valve output – chilled / hot water valve. Voltage output (L)	2-pipe coil circuit valve output – chilled water valve. Voltage output (L)
	Valve 2	MTV2	Reserved	4-pipe coil circuit valve output – hot water valve. Voltage output (L)
	Voltage of electrical heater (Live)	HEAT	Voltage output (L), maximum 25 A	
Output	Stepping motor	CN1 / CN2	Louver stepping motor relay	
	Auxiliary contact 2	AUX2	Cooling mode signal relay (NO). Voltage free contact. To ensure the sensitivity of the connection, please make sure max wiring length < 5 m, 5 A	
	Auxiliary contact 1	AUX1	Heating mode signal switch (NO). Voltage free contact. To ensure the sensitivity of the connection, please make sure max wiring length < 5 m, 5 A	
	Serial BUS port	CN3	Master-slave network serial connection OR MODBUS / local PC host network serial connection.	

D.1.3. Wiring Diagram SK-NCSWC-001

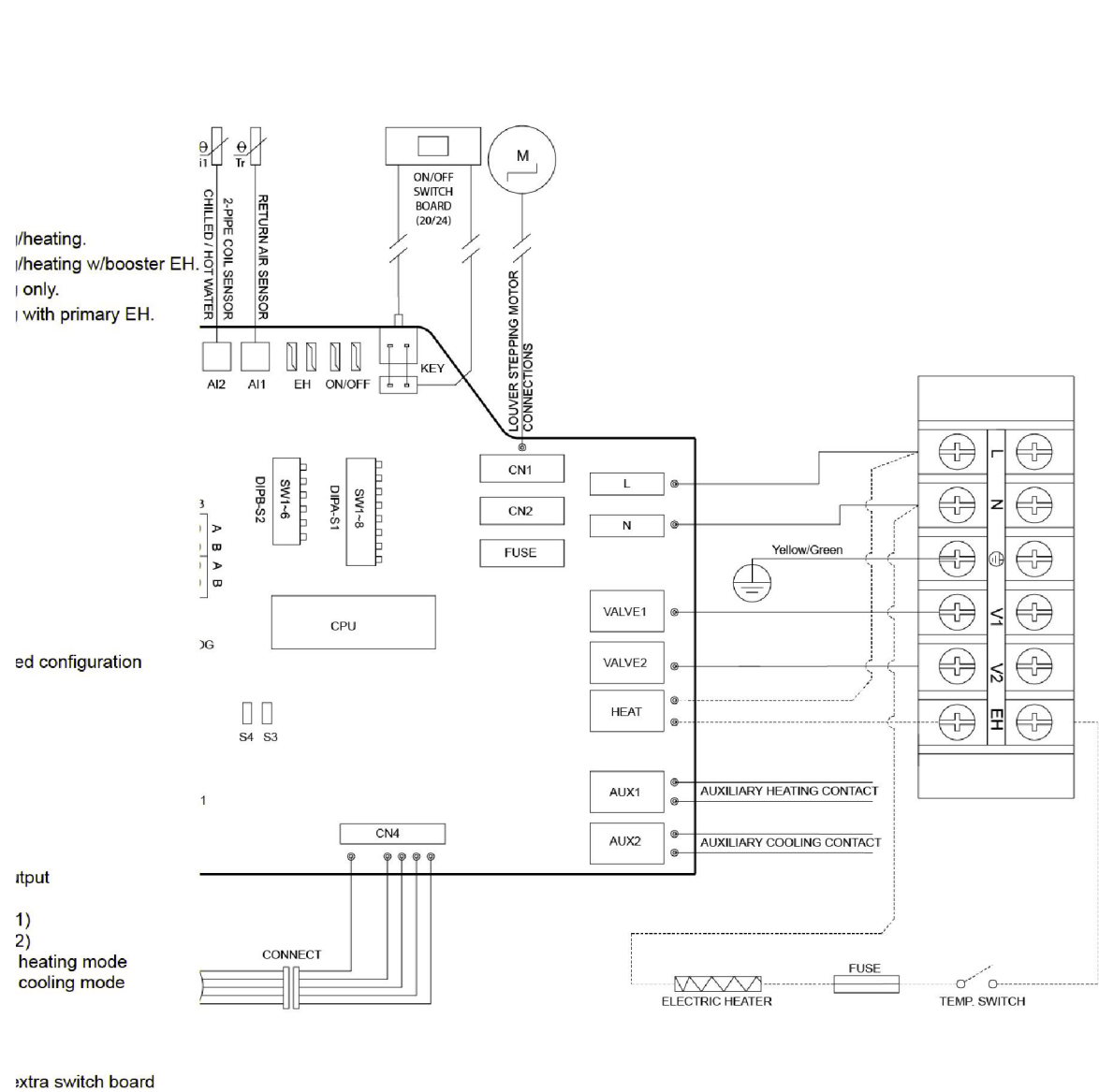

———— FACTORY
 - - - - - FIELD W

DIPA-S1
 SW1-5: set the un
 SW6: set unit type

Mode Configuratic
 SW7=0; SW8=0; i
 SW7=0; SW8=1; i
 SW7=1; SW8=0; i
 SW7=1; SW8=1; i

DIPB-S2
 SW1: Occupancy
 SW2: Unit configu
 0=2pipe s
 1=4-pipe s
 SW3: ON/OFF val
 0= no valve
 1=with valve
 SW4: Preheat set
 0= 36°C
 1= 28°C
 SW5, SW6, S3 (S

I/O Contacts
 L/N: 230VAC Pow
 Valve 1: 230VAC (i
 (2-pipe: c
 (4-pipe: c
 Valve 2: 230VAC (i
 (4-pipe: h
 HEAT: 230VAC Eli
 AI1: Return air ten
 AI2: Indoor coil ter
 AI3: Indoor coil ter
 AUX1: Voltage fre
 AUX2: Voltage fre
 ON/OFF: Occupar
 CN1~2: Stepping
 CN3: Serial BUS (i
 CN4: 230VAC fan
 KEY: ON/OFF swi

//heating.
 //heating w/booster EH.
 //only.
 //with primary EH.

ed configuration

input
 1)
 2)
 heating mode
 cooling mode

extra switch board

heating.
 heating w/booster EH.
 only.
 with primary EH.

d configuration

put
)
)
 heating mode
 :ooling mode

tra switch board

D.1.4. Configuration Settings

There are 2 DIP switches set on the PCB:

1. DIPA-S1 (8 positions)
 - SW1 – SW6: used for master-slave / BMS network address.
 - SW7 – SW8: used for operating mode configuration.
2. DIPB-S2 (6 positions)
 - SW1: Occupancy / economy mode selection.
 - SW2: 2-pipe / 4-pipe configuration selection.
 - SW3: Thermoelectric valve configuration selection (2-pipe system only).
 - SW4: Pre-heat protection temperature selection.
 - SW5 – SW6: brushless DC fan motor configuration.

1. Default DIP Switch Settings:

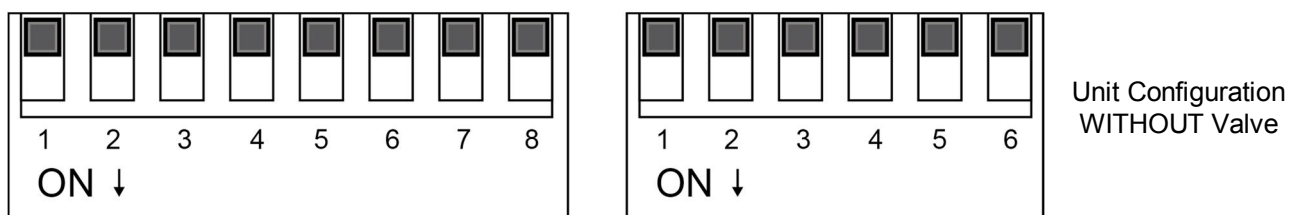

Figure 1

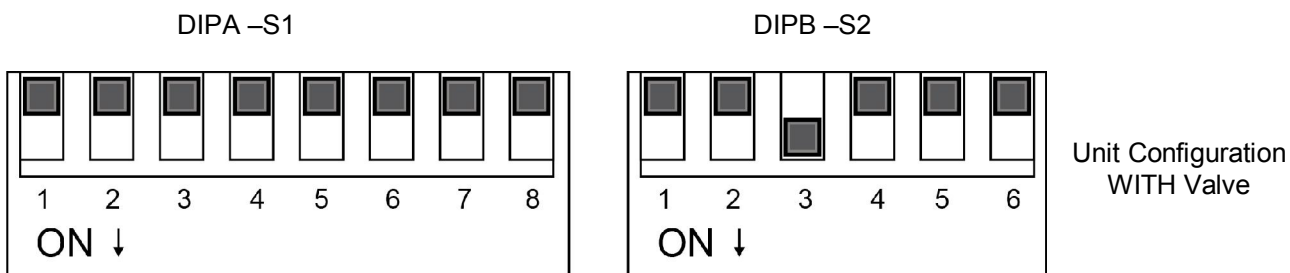

Figure 2

2. Thermoelectric Valve Configuration:

An on board dip switch SW3 of DIPB is used for this configuration.

SW3	Thermoelectric valve (MTV)
1	With valve
0	No valve

0=OFF
1=ON

3. Unit Configuration:

On board DIP Switch on DIPB are used for below configuration.

SW1	PR-O contact setting
0	Economy contact
1	Window contact

SW2	System setting
0	2-pipes system
1	4-pipes system

SW4	Preheat setting
1	28°C
0	36°C

4. Motorized Fan Speed Settings for Different Models:

Unit Model	Speed (RPM)			S3	SW5	SW6
	Low	Medium	High			
SWC-04	500	600	700	0	0	0
SWC-06	600	700	900	0	1	0
SWC-12	600	700	900	0	0	1
SWC-15	700	800	1100	0	1	1
SWC-18	900	1100	1300	1	0	0
SWC-20	800	900	1100	1	1	0
SWC-24	900	1200	1350	1	0	1
Default RPM	700	800	1100	1	1	1

5. Mode configuration:

DIPA-S1		Model
SW7	SW8	Model setting
0	0	Cool-Heat
0	1	Cool-Heat + booster heater
1	0	Cooling only
1	1	Cool + primary heater

6. Air Conditioner ON/OFF

There are 3 ways to turn the system on or off:

- By the ON/OFF button on the handset or wired wall pad.
- By the programmable timer on the handset or wired wall pad.
- By the manual control button on the air conditioner.

7. Power On Setting

- When the power on signal is received by the air conditioner, the Mode, Fan Speed, Setting temperature and Swing setting will be the same as the handset setting before the last power off.
- When the power on signal is received by the air conditioner, the Mode, Fan Speed, Setting temperature, Swing setting and Timer ON/OFF weekly program will be the same as wall pad setting before the last power off.

D.1.5. Control Logics For 2-Pipe System

D.1.5.1. With Thermoelectric Valve Configuration

COOL MODE

- a) MTV2, AUX1 and heater are always off.
- b) If $T_r \geq T_s + 1^\circ\text{C}$ (or $+ 4^\circ\text{C}$ if economy contact is activated), cool operation is activated, MTV1 and AUX2 are turned on. Indoor fan runs at set speed.
- c) If $T_r < T_s$, cool operation is terminated, MTV1 and AUX2 are turned off. Indoor fan runs at set speed.
- d) The range of T_s is $16 - 30^\circ\text{C}$
- e) Indoor fan speed can be adjusted for low, medium, high and auto.
- f) When turned on, MTV1 requires 30 seconds before it is fully open.
- g) When turned off, MTV1 requires 120 seconds before it is fully closed.
- h) When the unit is turned off, indoor fan will delay for 5 seconds before it is turned off.

LOW TEMPERATURE PROTECTION OF INDOOR COIL

- a) If $T_{i1} \leq 2^\circ\text{C}$ for 2 minutes, MTV1 and AUX2 are turned off. If indoor fan is set for low speed, it will run at medium speed. If it is set at medium or high speed, it will keep running at the same speed.
- b) If $T_{i1} \geq 5^\circ\text{C}$ for 2 minutes, MTV1 and AUX2 are turned on. Indoor fan runs at set speed.

FAN MODE

- a) Indoor fan runs at the set speed while heater, MTV1, MTV2, AUX1 and AUX2 are turned off.
- b) Indoor fan speed can be adjusted for low, medium and high.

HEAT MODE

Heat Mode without Electrical Heater

- a) MTV2, AUX2 and heater are always off.
- b) If $T_r \leq T_s - 1^\circ\text{C}$ (or $- 4^\circ\text{C}$ if economy contact is activated), heat operation is activated, MTV1 and AUX1 are turned on. Indoor fan runs at the set speed.
- c) If $T_r > T_s$, heat operation is terminated, MTV1 and AUX1 are turned off. Indoor fan runs at 200RPM.
- d) The range of T_s is $16 - 30^\circ\text{C}$.
- e) Indoor fan speed can be adjusted for low, medium, high and auto.
- f) MTV1 will delay for 30 seconds before it is turned on.
- g) MTV1 will delay for 120 seconds before it is turned off.

Heat Mode with Electrical Heater as Booster

- a) MTV2 and AUX2 are always off.
- b) If $T_r \leq T_s - 1^\circ\text{C}$ (or $- 4^\circ\text{C}$ if economy contact is activated), heat operation is activated, MTV1 and AUX1 are turned on. Indoor fan runs at the set speed.
- c) If $T_r > T_s$, heat operation is terminated, MTV1 and AUX1 are turned off. Indoor fan runs at 200RPM.
- d) If $T_{i1} < 40^\circ\text{C}$, the electrical heater is turned on. If $40 \leq T_{i1} < 45^\circ\text{C}$, the electrical heater is kept original state. If $T_{i1} \geq 45^\circ\text{C}$, the electrical heater is turned off.
- e) The range of T_s is $16 - 30^\circ\text{C}$.
- f) Indoor fan speed can be adjusted for low, medium, high and auto.
- g) MTV1 will delay for 30 seconds before it is turned on.
- h) MTV1 will delay for 120 seconds before it is turned off.

Heat Mode with Electrical Heater as Primary Heat Source

- a) MTV1, MTV2 , and AUX2 are always off.
- b) If $T_{i2} \leq 30^{\circ}\text{C}$ (or T_{i2} is damaged or not connected),
 - 1) If $T_r \leq T_s - 1^{\circ}\text{C}$ (or -4°C if economy contact is activated), heat operation is activated, electrical heater and AUX1 are turned on. Indoor fan runs at set speed.
 - 2) If $T_r > T_s$, heat operation is terminated, Electrical heater and AUX1 are turned off. Indoor fan runs at 200RPM.
- c) If $T_{i2} > 30^{\circ}\text{C}$, MTV2 and AUX2 is off.
 - 1) If $T_r \leq T_s - 1^{\circ}\text{C}$ (or -4°C if economy contact is activated), heat operation is activated, Electrical heater are turned off. MTV1 and AUX1 are turned on. fan runs at set speed.
 - 2) If $T_r > T_s$, heat operation is terminated, MTV1 and AUX1 are turned off. Indoor fan runs at 200RPM.
- d) The range of T_s is $16 - 30^{\circ}\text{C}$.
- e) Indoor fan speed can be adjusted for low, medium, high and auto.

PRE-HEAT

Pre-Heat without Electrical Heater

- a) If $T_{i1} < 36^{\circ}\text{C}$ (or 28°C depends on DIP setting), when MTV1 and AUX1 are on, indoor fan runs at 200RPM.
- b) If $T_{i1} \geq 38^{\circ}\text{C}$ (or 30°C depends on DIP setting), when MTV1 and AUX1 are on, indoor fan runs at set speed.
- c) If indoor coil temperature sensor is damaged, pre-heat time is set for 2 minutes and indoor fan runs at set speed.

Pre-Heat with Electrical Heater

- a) If Indoor fan speed $\geq 300\text{RPM}$, electrical heater will turned on.

POST-HEAT

Post-Heat without Electrical Heater

- a) If $T_{i1} \geq 38^{\circ}\text{C}$, MTV1 and AUX1 are off, indoor fan continues to run at set speed.
- b) If $36^{\circ}\text{C} \leq T_{i1} \leq 38^{\circ}\text{C}$, when MTV1 and AUX1 are off. Indoor fan keeps original state.
- c) If $T_{i1} < 36^{\circ}\text{C}$, MTV1 and AUX1 are off. Indoor fan runs at 200RPM.
- d) If indoor coil temperature coil is damaged, post-heat time is set for 3 minutes with indoor fan running at set speed.

Post-Heat with Electrical Heater

- a) Indoor fan will runs at 200RPM before the unit off for 20 seconds.

Over-heat Protection of Indoor Coil

- a) If $T_{i1} \geq 75^{\circ}\text{C}$, MTV1 and AUX1 are off, indoor fan remains on and runs at high speed.
- b) If $T_{i1} < 70^{\circ}\text{C}$, MTV1 and AUX1 are on, indoor fan remains on and runs at set speed.
- c) If indoor coil temperature sensor is damaged, the protection mode will become obsolete and the unit will work according to the Pre-heat and Post-heat program.

DEHUMIDIFICATION MODE

- a) MTV2, AUX1 and heater are always off.
- b) If $Tr \geq 25^{\circ}\text{C}$, MTV1 and AUX2 will be on for 3 minutes, and off for 4 minutes.
- c) If $16^{\circ}\text{C} \leq Tr < 25^{\circ}\text{C}$, MTV1 and AUX2 will be on for 3 minutes, and off for 6 minutes.
- d) If $Tr < 16^{\circ}\text{C}$, MTV1 and AUX2 will be turned off for 4 minutes.
- e) At the end of the above dehumidification cycle, system will decide the next dehumidification control option. Indoor fan will run at low speed throughout the dehumidification process.

AUTO-MODE

Without Electrical and with Electric Heater as Booster

- a) Every time the unit is turned on, MTV1 is on AUX1, AUX2 and fan is off. MTV2 and heater are always off. After 120 seconds, decide the subsequent operation mode as follow:
 - 1) If the coil temperature sensor ($Ti1$) $\geq 36^{\circ}\text{C}$, MTV1, AUX1 and fan turn on or off according to HEAT mode.
 - 2) If $Ti1 < 36^{\circ}\text{C}$, MTV1, AUX2 and fan turn on or off according to COOL mode.
- b) Unit remains in AUTO COOL or AUTO HEAT mode throughout the operating cycle until the user changes the mode manually or restarts the unit.
- c) Should there be failure of $Ti1$ sensor, auto mode is not allowed.

With Electric Heater as Primary Heat Source

- a) If current running mode is AUTO COOL mode, it will change over to AUTO HEAT mode upon satisfy all the conditions below:
 - 1) $Ts - Tr \geq 1.0^{\circ}\text{C}$ (or $- 4^{\circ}\text{C}$ if economy contact is activated).
 - 2) MTV1 has stop ≥ 10 minutes.
- b) If current running mode is AUTO HEAT mode, it will change over to AUTO COOL mode upon satisfy all the conditions below:
 - 1) $Tr - Ts \geq 1.0^{\circ}\text{C}$ (or $+ 4^{\circ}\text{C}$ if economy contact is activated).
 - 2) MTV1 has stop ≥ 10 minutes.

Note: AUTO COOL or AUTO HEAT operations are the same as COOL or HEAT mode respectively.

D.1.5.2. Without Thermoelectric Valve Configuration

COOL MODE

- a) Heater, AUX1, MTV1 and MTV2 are always off.
- b) If $Tr \geq Ts + 1^{\circ}\text{C}$ (or $+ 4^{\circ}\text{C}$ if economy contact is activated), cool operation is activated, AUX2 is on. Indoor fan runs at set speed.
- c) If $Tr < Ts$, cool operation is terminated, AUX2 is off. Indoor fan is turned off.
- d) The range of Ts is $16 - 30^{\circ}\text{C}$.
- e) Indoor fan speed can be adjusted for low, medium, high and auto.
- f) When the unit is turned off, indoor fan will delay for 5 seconds before it is turned off.

LOW TEMPERATURE PROTECTION OF INDOOR COIL

- a) If $Ti1 \leq 2^{\circ}\text{C}$ for 2 minutes, AUX2 is off. If low speed is selected via user interface, indoor fan runs at medium speed. If medium or high speed is selected via user interface, indoor fan runs at set speed.
- b) If $Ti1 \geq 5^{\circ}\text{C}$ for 2 minutes, AUX2 is on. Indoor fan runs at set speed.

FAN MODE

- a) Indoor fan runs at the set speed while heater, AUX1, AUX2, MTV1 and MTV2 are turned off.
- b) Indoor fan speed can be adjusted for low, medium and high.

HEAT MODE

Heat Mode without Electrical Heater

- a) MTV1, MTV2, AUX2 and heater are always off.
- b) If $T_r \leq T_s - 1^\circ\text{C}$ (or $- 4^\circ\text{C}$ if economy contact is activated), heat operation is activated, AUX1 is turned on. Indoor fan runs at the set speed.
- c) If $T_r > T_s$, heat operation is terminated, AUX1 is turned off. Indoor fan runs at 200RPM.
- d) The range of T_s is $16 - 30^\circ\text{C}$.
- e) Indoor fan speed can be adjusted for low, medium, high and auto.

Heat Mode with Electrical Heater as Booster

- a) MTV1, MTV2 and AUX2 are always off.
- b) If $T_r \leq T_s - 1^\circ\text{C}$ (or $- 4^\circ\text{C}$ if economy contact is activated), heat operation is activated, AUX1 is turned on. Indoor fan runs at the set speed.
- c) If $T_r > T_s$, heat operation is terminated, AUX1 is turned off. Indoor fan runs at 200RPM.
- d) If $T_{i1} < 40^\circ\text{C}$, the electrical heater is turned on. If $40 \leq T_{i1} < 45^\circ\text{C}$, the electrical heater is kept original state. If $T_{i1} \geq 45^\circ\text{C}$, the electrical heater is turned off.
- e) The range of T_s is $16 - 30^\circ\text{C}$.
- f) Indoor fan speed can be adjusted for low, medium, high and auto.

PRE-HEAT

Pre-Heat without Electrical Heater

- a) MTV1, MTV2 and AUX2 are off.
- b) If $T_{i1} < 36^\circ\text{C}$ (or $> 28^\circ\text{C}$ is selected by DIPB-S2 position SW4), AUX1 is on while indoor fan remains off.
- c) If $T_{i1} \geq 38^\circ\text{C}$ (or $< 30^\circ\text{C}$ is selected by DIPB-S2 position SW4), AUX1 is on while indoor fan runs at set speed.
- d) If indoor coil temperature sensor is damaged, pre-heat time is set for 2 minutes and indoor fan runs at set speed.

Pre-Heat with Electrical Heater

- a) If Indoor fan speed $\geq 300\text{RPM}$, electrical heater will turned on.

POST-HEAT

Post-Heat with and without Electrical Heater

- a) AUX1 is off. Electrical heater is turned off.
- b) Indoor fan will turn off after the unit is turned off 20 seconds AUX1 is off.

LOW TEMPERATURE PROTECTION OF INDOOR COIL

- a) If $T_{i1} \leq 2^\circ\text{C}$ for 2 minutes, AUX2 is off. If indoor fan runs at low speed, it will run at medium speed. If indoor fan runs at medium or high speed, it will run at set speed.
- b) If $T_{i1} \geq 5^\circ\text{C}$ for 2 minutes, AUX2 is on. Indoor fan runs at set speed.

OVER-HEAT PROTECTION OF INDOOR COIL

- a) If $T_{i1} \geq 75^\circ\text{C}$, AUX1 is turned off, indoor fan remains on and runs at high speed.
- b) If $T_{i1} < 70^\circ\text{C}$, AUX1 is turned on, indoor fan remains and runs at set speed.
- c) If indoor coil temperature sensor is damaged, the protection mode will become obsolete and the unit will work as the Pre-heat and Post-heat program.

DEHUMIDIFICATION MODE

- a) MTV1, MTV2, AUX1 and heater are always off.
- b) If $T_r \geq 25^\circ\text{C}$, indoor fan and AUX2 will be on for 3 minutes, and off for 4 minutes.
- c) If $16^\circ\text{C} \leq T_r < 25^\circ\text{C}$, indoor fan and AUX2 will be on for 3 minutes, and off for 6 minutes.
- d) If $T_r < 16^\circ\text{C}$, indoor fan and AUX2 will be turned off for 4 minutes.
- e) At the end of the above dehumidification cycle, system will decide the next dehumidification control option. Indoor fan will run at low speed throughout the dehumidification process.

AUTO-MODE

Not allowed.

D.1.6. Control Logics For 4-Pipe System

Note: unit equipped with 4x2 switching device.

COOL MODE

- a) MTV2, AUX1 and heater are always off.
- b) If $T_r \geq T_s + 1^\circ\text{C}$ (or $+4^\circ\text{C}$ if economy contact is activated), cool operation is activated, MTV1 and AUX2 are turned on. Indoor fan runs at set speed.
- c) If $T_r < T_s$, cool operation is terminated, MTV1 and AUX2 are turned off. Indoor fan runs at set speed.
- d) The range of T_s is $16 - 30^\circ\text{C}$.
- e) Indoor fan speed can be adjusted for low, medium, high and auto.
- f) When turned on, MTV1 requires 30 seconds before it is fully open.
- g) When turned off, MTV1 requires 120 seconds before it is fully closed.
- h) When the unit is turned off, indoor fan will delay for 5 seconds before it is turned off.

FAN MODE

- a) Indoor fan runs at the set speed while heater, MTV1, MTV2, AUX1 and AUX2 are turned off.
- b) Indoor fan speed can be adjusted for low, medium and high.

HEAT MODE

Heat Mode without Electrical Heater

- a) MTV1, AUX2 and heater always off.
- b) If $T_r \leq T_s - 1^\circ\text{C}$ (or -4°C if economy contact is activated), heat operation is activated, MTV2 and AUX1 are turned on. Indoor fan runs at the set speed.
- c) If $T_r > T_s$, heat operation is terminated, MTV2 and AUX1 are turned off. Indoor fan runs at 200RPM.
- d) The range of T_s is $16 - 30^\circ\text{C}$.
- e) Indoor fan speed can be adjusted for low, medium, high and auto.
- f) MTV2 will delay for 30 seconds before it is turned on.
- g) MTV2 will delay for 120 seconds before it is turned off.

Heat Mode with Electrical Heater as Booster

- a) MTV1 and AUX2 are always off.
- b) If $T_r \leq T_s - 1^\circ\text{C}$ (or -4°C if economy contact is activated), heat operation is activated, MTV2 and AUX1 are turned on. Indoor fan runs at the set speed.
- c) If $T_r > T_s$, heat operation is terminated, MTV2 and AUX1 are turned off. Indoor fan runs at 200RPM.
- d) If $T_{i1} < 40^\circ\text{C}$, the electrical heater is turned on. If $40 \leq T_{i1} < 45^\circ\text{C}$, the electrical heater is kept original state. If $T_{i1} \geq 45^\circ\text{C}$, the electrical heater is turned off.
- e) The range of T_s is $16 - 30^\circ\text{C}$.
- f) Indoor fan speed can be adjusted for low, medium, high and auto.
- g) MTV2 will delay for 30 seconds before it is turned on.
- h) MTV2 will delay for 120 seconds before it is turned off.

PRE-HEAT

Pre-heat without Electrical Heater

- a) If $T_{i1} < 36^{\circ}\text{C}$ [or 28°C depends on DIP setting], when MTV2 and AUX1 are on, Indoor fan runs at 200RPM.
- b) If $T_{i1} \geq 38^{\circ}\text{C}$ [or 30°C depends on DIP setting], when MTV2 and AUX1 are on, indoor fan runs at set speed.
- c) If indoor coil temperature sensor is damaged, pre-heat time is set for 2 minutes and indoor fan runs at set speed.

Pre-heat with Electrical Heater

- a) MTV2 and AUX2 turn on.
- b) If Indoor fan speed $\geq 300\text{RPM}$, electrical heater will turned on.

POST-HEAT

Post-heat without Electrical Heater

- a) If $T_{i2} \geq 38^{\circ}\text{C}$, when MTV2 and AUX 1 are off, indoor fan continues to run at set speed.
- b) If $36^{\circ}\text{C} \leq T_{i2} \leq 38^{\circ}\text{C}$, when MTV2 and AUX1 are off. Indoor fan keeps original state.
- c) If $T_{i2} < 36^{\circ}\text{C}$, when MTV2 and AUX1 are off. Indoor fan runs 30 seconds and stop 3 minutes repeatedly.
- d) If indoor coil temperature coil is damaged, post-heat time is set for 3 minutes with indoor fan running at set speed.

Post-heat with Electrical Heater

- a) Indoor fan runs at 200RPM after the unit off for 20 seconds.

LOW TEMPERATURE PROTECTION OF INDOOR COIL

- a) If $T_{i1} \leq 2^{\circ}\text{C}$ for 2 minutes, MTV1 and AUX2 are turned off. If indoor fan is set for low speed, it will run at medium speed. If it is set at medium or high speed, it will keep running at the same speed.
- b) If $T_{i1} \geq 5^{\circ}\text{C}$ for 2 minutes, MTV1 and AUX2 are turned on. Indoor fun runs at set speed.

OVER HEAT PROTECTION OF INDOOR COIL

- a) If $T_{i2} \geq 75^{\circ}\text{C}$, MTV2 and AUX1 are turned off, indoor fan remains on and runs at high speed.
- b) If $T_{i2} < 70^{\circ}\text{C}$, MTV2 and AUX1 are turned on, indoor fan remains on and runs at set speed.
- c) If indoor coil temperature sensor is damaged, the protection mode will become obsolete and the unit will work as the Pre-heat and Post-heat set times.

DEHUMIDIFICATION MODE

- a) MTV2, AUX1 and heater are always off.
- b) If $T_r \geq 25^{\circ}\text{C}$, MTV1 and AUX2 will be on for 3 minutes, and off for 4 minutes.
- c) If $16^{\circ}\text{C} \leq T_r < 25^{\circ}\text{C}$, MTV1 and AUX2 will be on for 3 minutes, and off for 6 minutes.
- d) If $T_r < 16^{\circ}\text{C}$, MTV1 and AUX2 will be turned off for 4 minutes.

At the end of the above dehumidification cycle, system will decide the next dehumidification control option. Indoor fan will run at low speed throughout the dehumidification process.

AUTO-MODE

- a) If current running mode is AUTO COOL mode, it will change over to AUTO HEAT mode upon satisfy all the conditions below:
 - 1) $T_s - T_r \geq 1.0^{\circ}\text{C}$ (or $- 4^{\circ}\text{C}$ if economy contact is activated).
 - 2) MTV1 has stop ≥ 10 minutes.
- b) If current running mode is AUTO HEAT mode, it will change over to AUTO COOL mode upon satisfy all the conditions below:
 - 1) $T_r - T_s \geq 1.0^{\circ}\text{C}$ (or $+ 4^{\circ}\text{C}$ if economy contact is activated).
 - 2) MTV2 has stop ≥ 10 minutes.

Note: AUTO COOL or AUTO HEAT operations are the same as COOL or HEAT mode respectively.

SLEEP MODE

- a) SLEEP mode can only be set in COOL or HEAT modes.
- b) In COOL mode, after SLEEP mode is set, the indoor fan will run at low speed and T_s will increase 2°C during 2 hours.
- c) In HEAT mode, after SLEEP mode is set, the indoor fan will run at set speed and T_s will decrease 2°C during 2 hours.
- d) Changing of operation mode will cancel SLEEP mode.

The COOL mode SLEEP profile is:

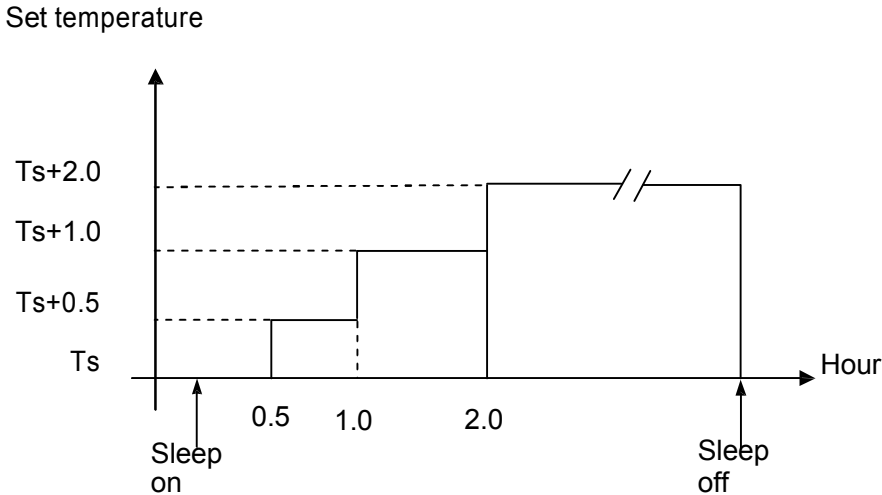

The HEAT mode sleep profile is:

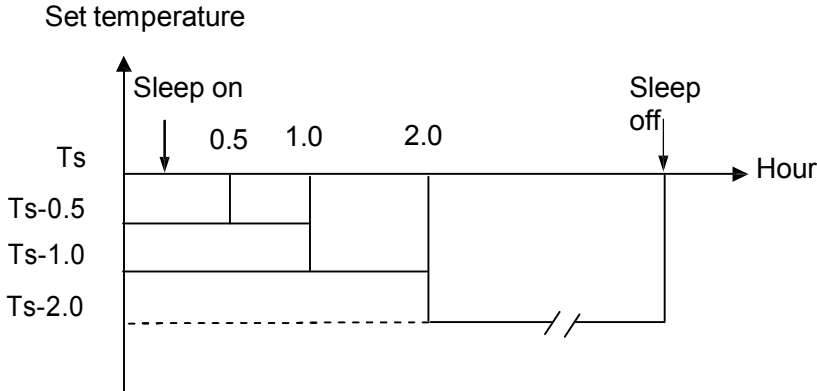

D.1.7. Auto Fan Speed

- a) In COOL mode, the fan speed cannot change until it has run at this speed for more than 30 seconds. Fan speed is regulated according to the profile below.

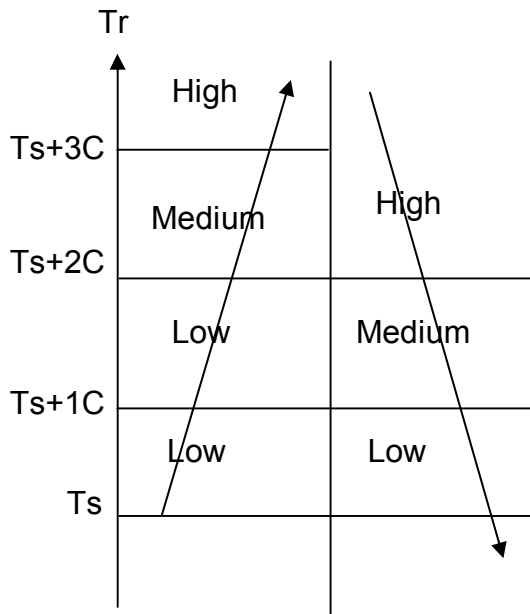

- b) In HEAT mode, the fan speed cannot change until it has run at this speed for more than 30 seconds.

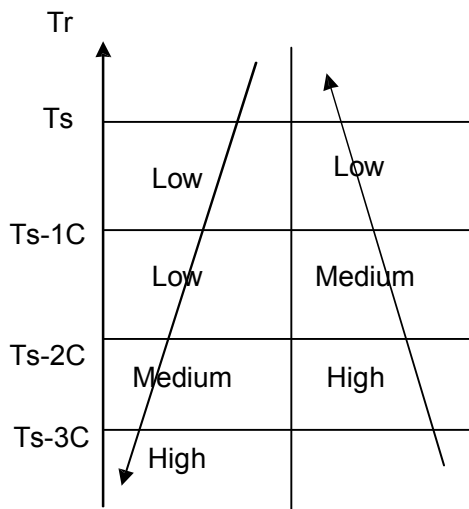

D.1.8. Louver

For remote handset

Whenever indoor fan is running, louver can swing or stop at the desired position.

Louver angle: 0~100°, opens clockwise with largest angle at 100°.

Swing angle: 35~100°, opens clockwise to 68°. Below are the 4 fixed positions which can be set from wireless LCD handset.

Position	Angle
1	35°
2	57°
3	83°
4	100°

For wired wall pad

Louver angle: 0~100°, opens clockwise, and with biggest angle at 100°.

Swing angle: 35~100°, opens clockwise to 68°. User may stop louver at any desired position between 35~100°.

D.1.9. Buzzer

If a command is received by the air conditioner, the master unit will respond with 2 beeps for each setting, and the slave unit will respond with 1 beep.

D.1.10. Auto Restart

The system uses non-volatile memory to save the present operation parameters when system is turned off or in case of system failure or cessation of power supply. Operation parameters when using handset are mode, set temperature, swing, and fan speed. When using wall pad parameters are Mode, Set Temperature, Swing, and Fan Speed, including the 7-days Timer program are retained. When power supply resumes or the system is switched on again, the same operations as previously set will function.

D.1.11. Operation Of Control Panel On High-Wall Unit

D.1.11.1. On/Off Switch

- a) This is a tactile switch to select COOL → HEAT → OFF operation mode.
- b) In COOL mode, the set temperature of the system is 24°C with auto fan speed and swing. There are no timer and SLEEP modes.
- c) In HEAT mode, the set temperature of the system is 24°C with auto fan speed and swing. There are no timer and SLEEP modes.
- d) Master unit that does not use LCD wall pad will globally broadcast.

Note: When button pressing is effective, master unit buzzer will beep twice and slave unit beeps once.

D.1.11.2. Electric Heater Safety Switch (on control PCB)

Before the electrical heater is turned on, the EH safety switch must be closed. If this contact is opened continuously ≥ 1 second, heater must be cut off immediately and report error. Once the contact is returned to close position ≥ 60 seconds, reset the error and heater is allowed to cut in again.

Should EH safety switch be opened ≥ 3 times within 60 minutes, heater is not allowed to cut in anymore.

Turn off the unit to reset the fault provided that the switch has returned to close position.

D.2. LED lights

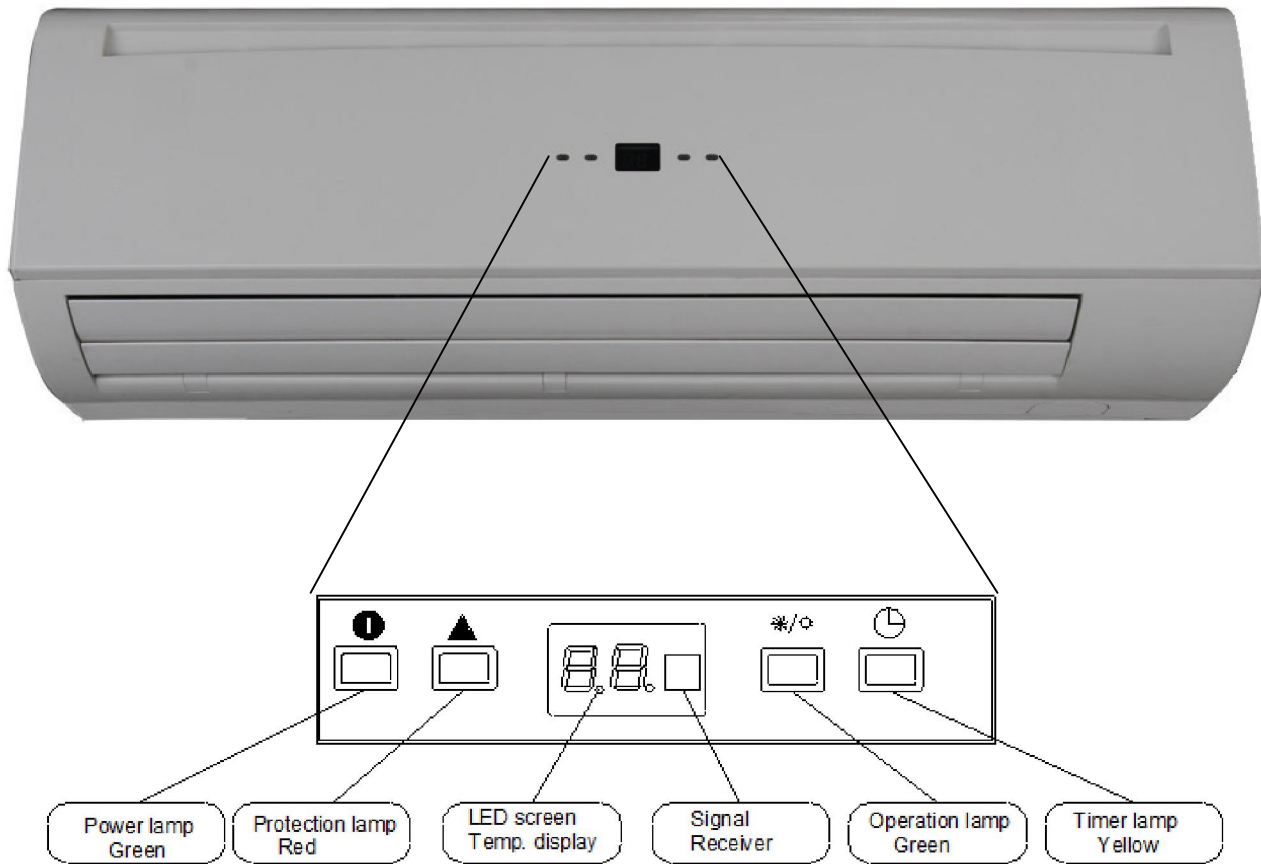

For all units Power / Operation LED light (both green)	
Unit on	Operation LED On, Power LED Off
Unit in standby	Power LED On, Operation LED Off

D.2.1. LED Indication and Error Description

For all units - Operation LED light (Green)			
Error Description	Blink	Reason	Remedy
Electrical heater failure	Green LED blink 1 times, stop 3 sec	<i>Only for unit with EH.</i> EH protection switches is opened.	<ol style="list-style-type: none"> 1. Change fan speed to high. 2. Replace the damaged protection switch of EH.
Indoor coil sensor 2 failure	Green LED blink 2 times, stop 3 sec	Ti2 sensor unplugged or damaged.	<ol style="list-style-type: none"> 1. Check Ti2 plug is connected or not. 2. Check sensor's resistance is correct or not.
Return air sensor failure	Green LED blink 3 times, stop 3 sec	Room sensor unplugged or damaged.	<ol style="list-style-type: none"> 1. Check Tr plug is connected or not. 2. Check sensor's resistance is correct or not.
Indoor coil sensor 1 failure	Green LED blink 4 times, stop 3 sec	Ti1 sensor unplugged or damaged.	<ol style="list-style-type: none"> 1. Check Ti1 plug is connected or not. 2. Check sensor's resistance is correct or not.
Indoor coil low temperature protection	Green LED blink 5 times, stop 3 sec	Water temperature is lower than 3 °C.	Check the water temperature.
Indoor coil over heat protection	Green LED blink 6 times, stop 3 sec	Water temperature is higher than 70 °C.	Check the water temperature
EC motor failure	Green LED blink 9 times, stop 3 sec	No EC motor feedback	<ol style="list-style-type: none"> 1. Check DIPB-SW5 and SW6 setting. 2. Check the EC motor.

D.2.2. LED indication on Master/Slave connection

For master unit indicating defect status of all slave units. Error message can be found in LED lights on master unit.

Master unit Protection LED light (Red)		
Unit No.	Blink	Remedy
Unit 2 failure	RED LED blink 2 times, stop 3 sec	Check unit 2 communication plug and fix it
Unit 3 failure	RED LED blink 3 times, stop 3 sec	Check unit 3 communication plug and fix it
Unit 4 failure	RED LED blink 4 times, stop 3 sec	Check unit 4 communication plug and fix it
Unit 5 failure	RED LED blink 5 times, stop 3 sec	Check unit 5 communication plug and fix it
Unit 6 failure	RED LED blink 6 times, stop 3 sec	Check unit 6 communication plug and fix it
Unit 7 failure	RED LED blink 7 times, stop 3 sec	Check unit 7 communication plug and fix it
Unit 8 failure	RED LED blink 8 times, stop 3 sec	Check unit 8 communication plug and fix it
Unit 9 failure	RED LED blink 9 times, stop 3 sec	Check unit 9 communication plug and fix it
Unit 10 failure	RED LED blink 10 times, stop 3 sec	Check unit 10 communication plug and fix it
Unit 11 failure	RED LED blink 11 times, stop 3 sec	Check unit 11 communication plug and fix it
Unit 12 failure	RED LED blink 12 times, stop 3 sec	Check unit 12 communication plug and fix it
Unit 13 failure	RED LED blink 13 times, stop 3 sec	Check unit 13 communication plug and fix it
Unit 14 failure	RED LED blink 14 times, stop 3 sec	Check unit 14 communication plug and fix it
Unit 15 failure	RED LED blink 15 times, stop 3 sec	Check unit 15 communication plug and fix it
Unit 16 failure	RED LED blink 16 times, stop 3 sec	Check unit 16 communication plug and fix it
Unit 17 failure	RED LED blink 17 times, stop 3 sec	Check unit 17 communication plug and fix it
Unit 18 failure	RED LED blink 18 times, stop 3 sec	Check unit 18 communication plug and fix it
Unit 19 failure	RED LED blink 19 times, stop 3 sec	Check unit 19 communication plug and fix it
Unit 20 failure	RED LED blink 20 times, stop 3 sec	Check unit 20 communication plug and fix it
Unit 21 failure	RED LED blink 21 times, stop 3 sec	Check unit 21 communication plug and fix it
Unit 22 failure	RED LED blink 22 times, stop 3 sec	Check unit 22 communication plug and fix it
Unit 23 failure	RED LED blink 23 times, stop 3 sec	Check unit 23 communication plug and fix it
Unit 24 failure	RED LED blink 24 times, stop 3 sec	Check unit 24 communication plug and fix it
Unit 25 failure	RED LED blink 25 times, stop 3 sec	Check unit 25 communication plug and fix it
Unit 26 failure	RED LED blink 26 times, stop 3 sec	Check unit 26 communication plug and fix it
Unit 27 failure	RED LED blink 27 times, stop 3 sec	Check unit 27 communication plug and fix it
Unit 28 failure	RED LED blink 28 times, stop 3 sec	Check unit 28 communication plug and fix it
Unit 29 failure	RED LED blink 29 times, stop 3 sec	Check unit 29 communication plug and fix it
Unit 30 failure	RED LED blink 30 times, stop 3 sec	Check unit 30 communication plug and fix it
Unit 31 failure	RED LED blink 31 times, stop 3 sec	Check unit 31 communication plug and fix it
Unit 32 failure	RED LED blink 32 times, stop 3 sec	Check unit 32 communication plug and fix it

D.3. Networking System

D.3.1. Master-Slave Network

The control PCB can be set either as a master unit or slave unit.

MASTER UNIT FUNCTION

- a) The master unit sends data on its setting to the slave unit.
- b) The master unit settings are Unit ON/OFF, Mode, Fan Speed, Timer, Clock, Set Temperature, Swing Function, and Sleep Function for handset operation.
- c) The master unit settings are Unit ON/OFF, Mode, Fan Speed, Timer, Clock, Set Temperature, Swing Function, and Sleep Function for wall pad operation.

SLAVE UNIT FUNCTION

- a) The slave unit receives data on its settings from the master unit.
- b) The slave unit is allowed to change to a locally desired setting by local controller as long as there are no subsequent changes to the settings of the master unit.
- c) The slave units can be set individually for timer on and off function by handset or wall pad. The handset cannot override wall pad timer and clock setting.

D.3.2. Master – Slave Network Setup

- 1) Disconnect the communication plug from the SK-NCSWC-001

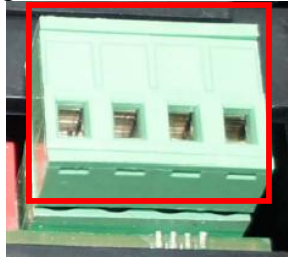

- 2) Communication plug

A, B, A, B is printed on the main PCB. When you connect the wires, please ensure connection of A to A and B to B.



- 3) Connection wire

- 3.1) If the total length of wire is more than 1000m, please use shielded wire in order to protect the signal transmission.
- 3.2) Complete wire connection

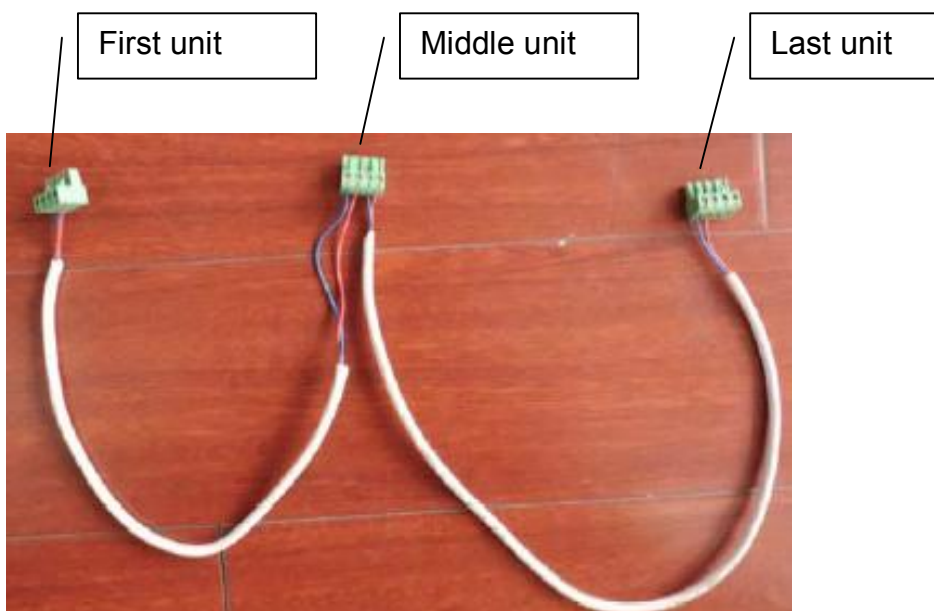

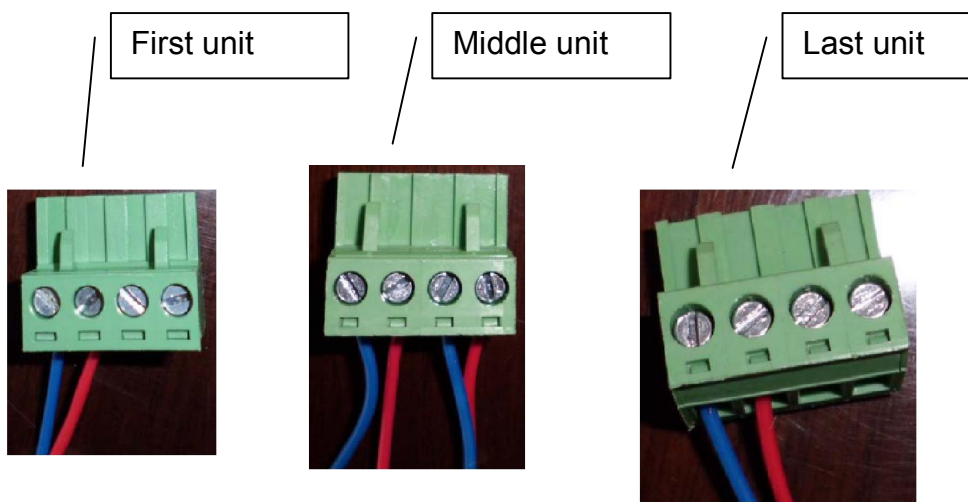

3.3) Wire connection check

3.3.1) After wire connection complete, please check the wire colour is correspondence.

3.3.2) Check the wire contact by using a multimeter.

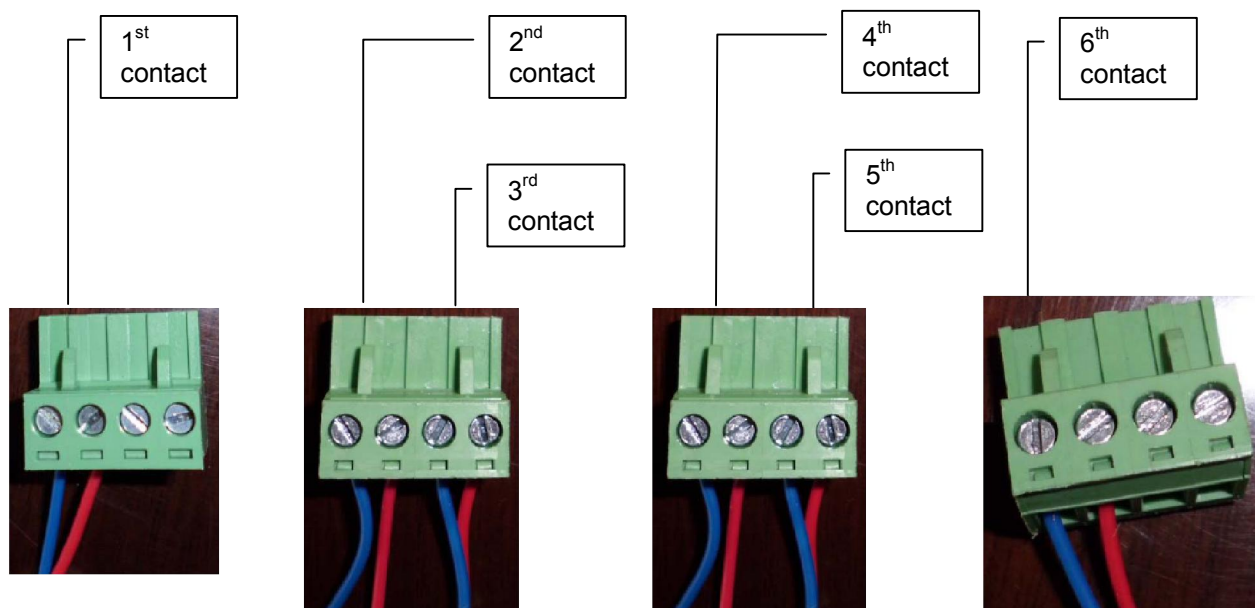

3.3.3) Check 1 and 2, 3 and 4, 5 and 6 to be sure connections correct.

3.3.4) If the resistance between two wire contacts is too high, please check and reconnect the wire contacts.

4) Reconnect the communication plug to control box

Using Remote Control Handset to Set Master Control Unit:

- a) Connect all the units PCBs according to the wire color and type of connector.
- b) Select the master unit by setting DIPA-S1 SW6 to ON (=1) in the PCB.
- c) Ensure the DIPA-S1 SW6 is set to OFF (=0) in the PCB on each slave unit.
- d) Switch on the units by connecting the main power supply.
- e) Using handset set the operation parameters for the Master unit which will automatically send the settings to the slave unit when pressing the "Network" button for 3 seconds.
- f) Master unit will beep twice confirming receipt of commands while Slave unit will beep once.

Using Wall pad to Set Master Control Unit:

- a) Connect all the units PCBs according to the wire color and type of connector.
- b) Select the master unit by setting DIPA-S1 SW6 to ON (=1) in the PCB.
- c) Ensure the DIPA-S1 SW6 is set to OFF (=0) in the PCB on each slave unit.
- d) Provide each slave unit an addressable code by configuring SW1 – SW5 of DIPA-S1 according to the DIP switch setting table.
- e) Switch on the units by connecting the main power supply.
- f) Using the wall pad set the operation parameters for the Master unit which will send the setting to the slave units based on Global-control communication or Addressable communication methods.
- g) Master unit will beep twice confirming receipt of commands while Slave unit will beep once.

MASTER-SLAVE CONTROL

The control PCB can receive data from both wireless LCD handset and wired wall pad.

D.3.3. Master-Slave Communication Method

There are two modes for Master-slave structure.

Global Control communication

Master will broadcast the settings to all slave units. During normal operation, slave units can receive commands from its wireless handset and wall pad control panel. Upon reception of master global commands, all slave unit settings will be replaced by the master settings.

Addressable communication

Master controller must be LCD wall pad. Slave unit parameters are set as usual. Upon receiving the control commands from a master, the addressed slave unit settings will be replaced by the master settings.

DIPA-S1 address setting: ON=1, OFF=0.

DIPA-S1 SW6	DIPA-S1 SW5	DIPA-S1 SW4	DIPA-S1 SW3	DIPA-S1 SW2	DIPA-S1 SW1	Unit No.	Remark
1	0	0	0	0	0	01	Master
0	0	0	0	0	1	02	Slave
0	0	0	0	1	0	03	Slave
0	0	0	0	1	1	04	Slave
0	0	0	1	0	0	05	Slave
0	0	0	1	0	1	06	Slave
0	0	0	1	1	0	07	Slave
0	0	0	1	1	1	08	Slave
0	0	1	0	0	0	09	Slave
0	0	1	0	0	1	10	Slave
0	0	1	0	1	0	11	Slave
0	0	1	0	1	1	12	Slave
0	0	1	1	0	0	13	Slave
0	0	1	1	0	1	14	Slave
0	0	1	1	1	0	15	Slave
0	0	1	1	1	1	16	Slave
0	1	0	0	0	0	17	Slave
0	1	0	0	0	1	18	Slave
0	1	0	0	1	0	19	Slave
0	1	0	0	1	1	20	Slave
0	1	0	1	0	0	21	Slave
0	1	0	1	0	1	22	Slave
0	1	0	1	1	0	23	Slave
0	1	0	1	1	1	24	Slave
0	1	1	0	0	0	25	Slave
0	1	1	0	0	1	26	Slave
0	1	1	0	1	0	27	Slave
0	1	1	0	1	1	28	Slave
0	1	1	1	0	0	29	Slave
0	1	1	1	0	1	30	Slave
0	1	1	1	1	0	31	Slave
0	1	1	1	1	1	32	Slave

If master unit is equipped with wireless handset only, it can only use Global-Control communication method. If it is equipped with wall pad, it can use both communication methods.

D.3.4. Unit Network Wiring Scheme

Wiring diagram for a master-slave network connection

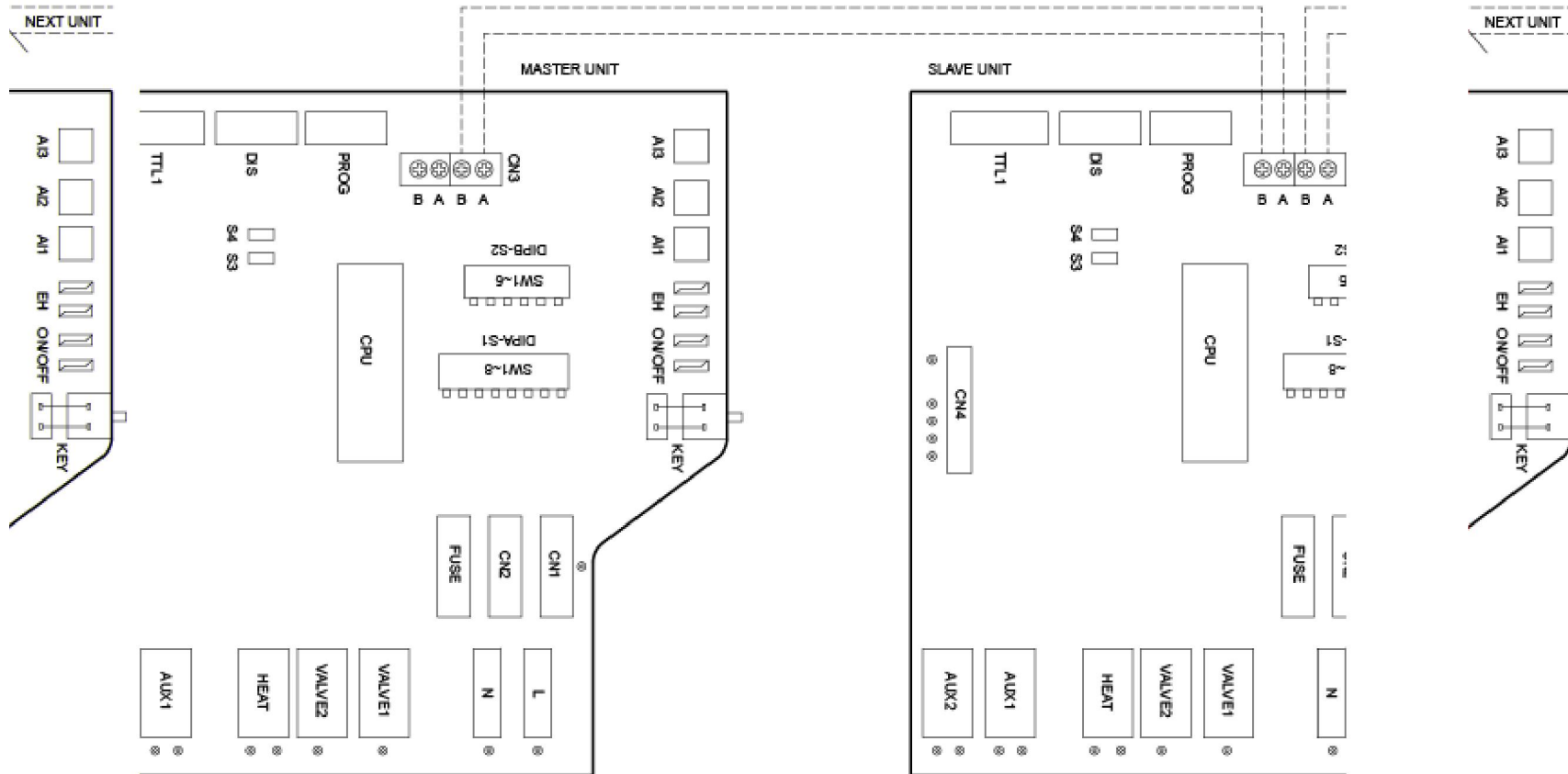

D.4. SK-NCSWC-002 Limited function FCU Controller

Used in all High-wall [V/P] ~W unit configurations.

Ti1 = Chilled water coil temperature (10K)

D.4.1. Definition of Input/Output

I/O		Code	2-Pipe
Analogue Input	Chilled water Sensor	AI1	Coil sensor
Power input	R1	Lo	230 Voltage input (NO). If any speed is powered, the unit is turned on. If no speed receives power, the unit is turned off.
	R 2	Med	
	R 3	Hi	
Power input	Phase	L	Power supply to the PCB and all the loads connected to the voltage outputs. Max length: 5 m.
	Neutral	N	Power supply to the PCB and all the loads connected to the voltage outputs. Max length: 5 m.
	Earth	GND	Power supply to the PCB and all the loads connected to the voltage outputs. Max length: 5 m.
Digital input	Wired wall pad	TTL	Change EC motor rpm
Signal input	AUTO SIGNAL	Auto	230V 50HZ, auto signal on, unit is turned on
	0 to+5VDC (0~10VDC)	Signal	0 to +5VDC · SW1=0 (0~10VDC, SW1=1)
Motor output	EC motor	CN3	
Output	Stepping motor	CN1-2	

D.4.2. Wiring diagram SK-NCSWC-002

D.4.3. Onboard configuration

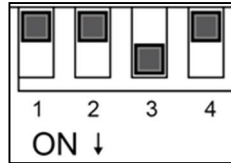

There is 1 DIP switch set on the PCB:

DIPB (4 positions)

- SW1: configured for different modulating signal
- SW2 – SW4: brushless DC fan motor configuration.

Code	State	Description
SW1	0	PCB configured for 0~5VDC modulating signal input.
	1	PCB configured for 0~10VDC modulating signal input.

MODEL	SW2	SW3	SW4	hi	Med	Low
SWC-04	0	0	0	700	600	500
SWC-06	0	0	1	900	700	600
SWC-12	0	1	0	900	700	600
SWC-15	0	1	1	1100	800	700
SWC-18	1	0	0	1300	1100	900
SWC-20	1	0	1	1100	900	800
SWC-24	1	1	0	1350	1200	900
Default RPM	1	1	1	Set by customer requirement		

D.4.4. Control Logics

1. Power On Setting

Any speed is powered, the unit is turned on. When all of relays are off, the unit is turned off.

2. Swing / Louver

When the unit is turned on, the louver will restore to the largest angle at 100°, then open to the operating angle at 87°. When the unit is turned off, the louver will close.

3. Signal Input

When Auto speed is turned ON, the unit is turned on and the motor runs at 200 RPM. EC motor RPM will be changed by the signal voltage.

D.4.5. LED Indication

For all units Power / Operation LED light (both green)	
Unit on	Operation LED On, Power LED Off
Unit in standby	Power LED On, Operation LED Off

D.4.6. Error Description

For all units - Operation LED light (Green)			
Item	Blink	Reason	Remedy
Indoor coil sensor 1 failure	Green LED blink 4 times, stop 3 sec	Ti1 sensor connection is not good or damaged.	1. Check Ti1 plug is good or not. 2. Check sensor's resistor is good or not.
EC motor failure	Green LED blink 9 times, stop 3 sec	No EC motor feedback	1. Check EC motor's wires connector. 2. Check the EC motor

D.5. Open Modbus protocol

Transfer Mode: RTU, BAUD Rate: 9600bps, 8 data bit, 1 stop bit, None parity bit

The communications require a delay between reading an answer and sending the next command of 80ms. All temperature is equal to reading data*10 accuracy: 0.1 degree C.

Supported Functions:

Function Code	Function Description
01(01H)	Read Coils
02(02H)	Read Discrete Inputs
03(03H)	Read Holding Registers
04(04H)	Read Input Registers
05(05H)	Write Single Coil
06(06H)	Write Single Register
15(0FH)	Write Multiple Coils
16(10H)	Write Multiple Registers
255(FFH)	Extended Commands which is used to test

Valid Error code table:

Error code	Description	Definition
01 (01H)	Invalid commands	Received commands beyond valid commands
02 (02H)	Invalid data address	Data addresses beyond valid data address
03 (03H)	Invalid data	Data beyond definition range
04 (04H)	Write data not succeed	Write data not succeed

Coils table:

Description	Address	Type*	Remark
Unit ON/OFF	100000	R/W	
Sleep mode	100001	R/W	
Louver swing	100002	R/W	
Reserved	100003		
Reserved	100004		
Reserved	100005		
Reserved	100006		
Reserved	100007		
Reserved	100008		
Reserved	100009		
Reserved	100010		
Reserved	100011		
Reserved	100012		
Reserved	100013		
Reserved	100014		
Reserved	100015		

* R = read only, W = write only, R/W = read and write.

Discrete table:

Description	Address	Type*	Remark
MTV1	200000	R	
MTV2	200001	R	
AUX1	200002	R	
AUX2	200003	R	
Condensate pump	200004	R	
Electrical heater	200005	R	
Wired wall pad	200006	R	
PRO	200007	R	
Float switch	200008	R	
Reserved	200009	R	
EH protection switch	200010	R	
Internal actually running and unit Unit ON/OFF	200011	R	Testing purpose only.

* R = read only, W = write only, R/W = read and write.

Holding Register table:

Description	Address	Type*	Remark
Mode setting	300000	R/W	Cooling mode = 01(H) Humidify mode = 02(H) Fan mode = 04(H) Heating mode = 08(H) Auto mode = 10(H)
Fan speed setting	300001	R/W	Low speed = 04(H) Medium speed = 02(H) High speed = 01(H) Auto fan speed = 07(H)
Louver swing setting	300002	R/W	Position 1 = 01(H) Position 2 = 02(H) Position 3 = 03(H) Position 4 = 04(H) Auto = 0F(H) Stop = 00(H)
Setting temperature	300003	R/W	16~30 degree C (actual*10 format)
Address setting	300004	R	Set by dip-switch, reading only
Reset	300005	W	=0x33 reset error
Week	300006	W	Calibration wired wall pad and set timer function
Hour	300007	W	Calibration wired wall pad and set timer function
Minute	300008	W	Calibration wired wall pad and set timer function
Second	300009	W	Calibration wired wall pad and set timer function
Hours in Timer on	300010	R/W	Timer ON
Minute in Timer on	300011	R/W	Timer ON
Hours in Timer off	300012	R/W	Timer OFF
Minute in Timer off	300013	R/W	Timer OFF
Icon of Timer ON or OFF	300014	R/W	BIT0 = Icon of Timer ON BIT1 = Icon of Timer OFF 1 = enable 0 = disable
Super low speed rpm	310000	R/W	200~1500
Low speed rpm	310001	R/W	200~1500
Medium speed rpm	310002	R/W	200~1500
High speed rpm	310003	R/W	200~1500
RPM setting	310004	R/W	0~2000 (used to test, 0 = disable)
Temperature sampling time	310005	R/W	2~100, default:5S
Factor of auto fan speed	310006	R/W	2~150, default:20
Factor of modulating valve	310007	R/W	2~250, default:150

* R = read only, W = write only, R/W = read and write.

Input Register table:

Description	Address	Type*	Remark
Dip switch 1 status	400000	R	
Dip switch 2 status	400001	R	
Room temperature sensor	400002	R	
Ti1 temperature sensor	400003	R	
Ti2 temperature sensor	400004	R	
Error code	400005	R	Bit0 = Room temperature sensor error Bit1 = Ti1 temperature sensor error Bit2 = Ti2 temperature sensor error Bit3 = Float switch error Bit4 = Indoor coil low temperature protection Bit5 = Indoor coil over heat protection Bit6 = Reserved Bit7 = Electrical heater failure Bit8 = Motor1 Error Bit9 = Motor2 Error Bit10 = System parameters error Bit11 = Reserved Bit12 = Reserved Bit13 = Reserved Bit14 = Reserved Bit15 = Reserved
Fan speed status	400006	R	Low = 04(H) Medium = 02(H) High = 01(H)
Mode status	400007	R	Cooling mode = 01(H) Dehumidify mode = 02(H) Fan mode = 04(H) Heating = 08(H)
Setting temperature status	400008	R	Testing only
Room temperature in wall pad status	400009	R	
Room temperature in main PCB status	400010	R	
Unit type	400011	R	4-pipe = 03, 2-pipe = 02 This setting is configured by dip switch
EC motor 1# RPM	400012	R	
EC motor 2# RPM	400013	R	

* R = read only, W = write only, R/W = read and write.

E. Users Interface

E.1. Remote Control Handset

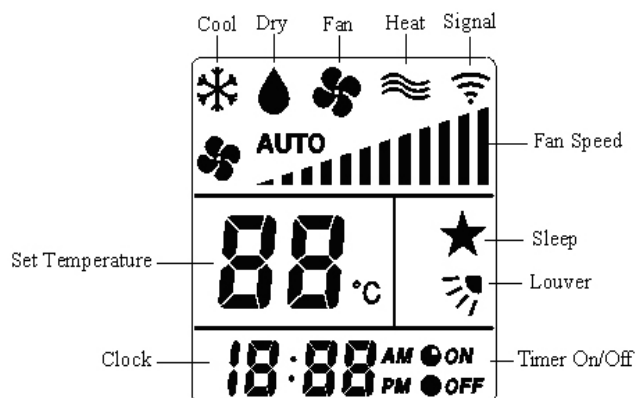
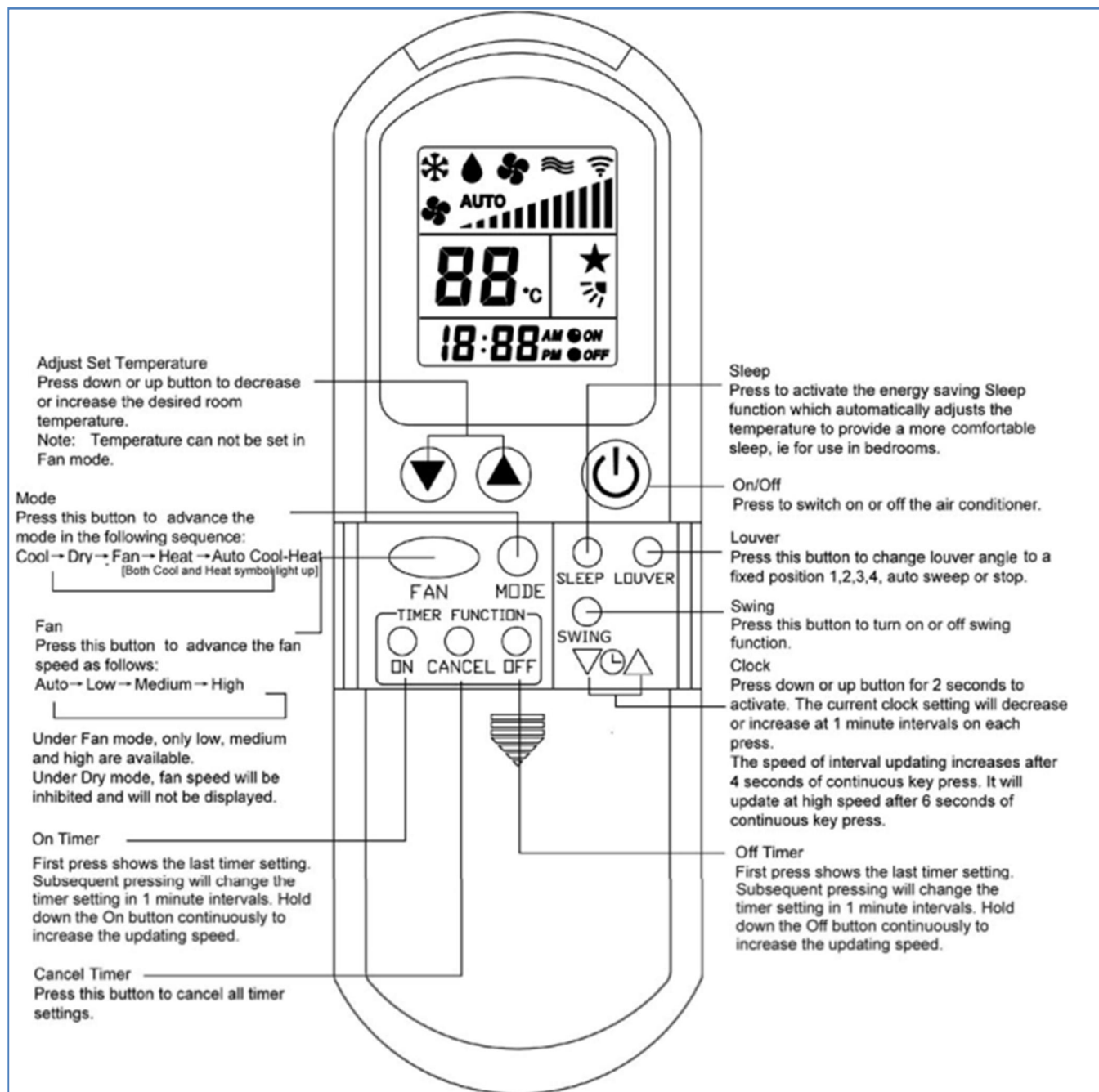

Attention

When unit with handset is master, settings are automatically sent to slaves;
Auto Cool-Heat operation will be applicable in 4-pipe system only.

Use "Swing" is not applicable

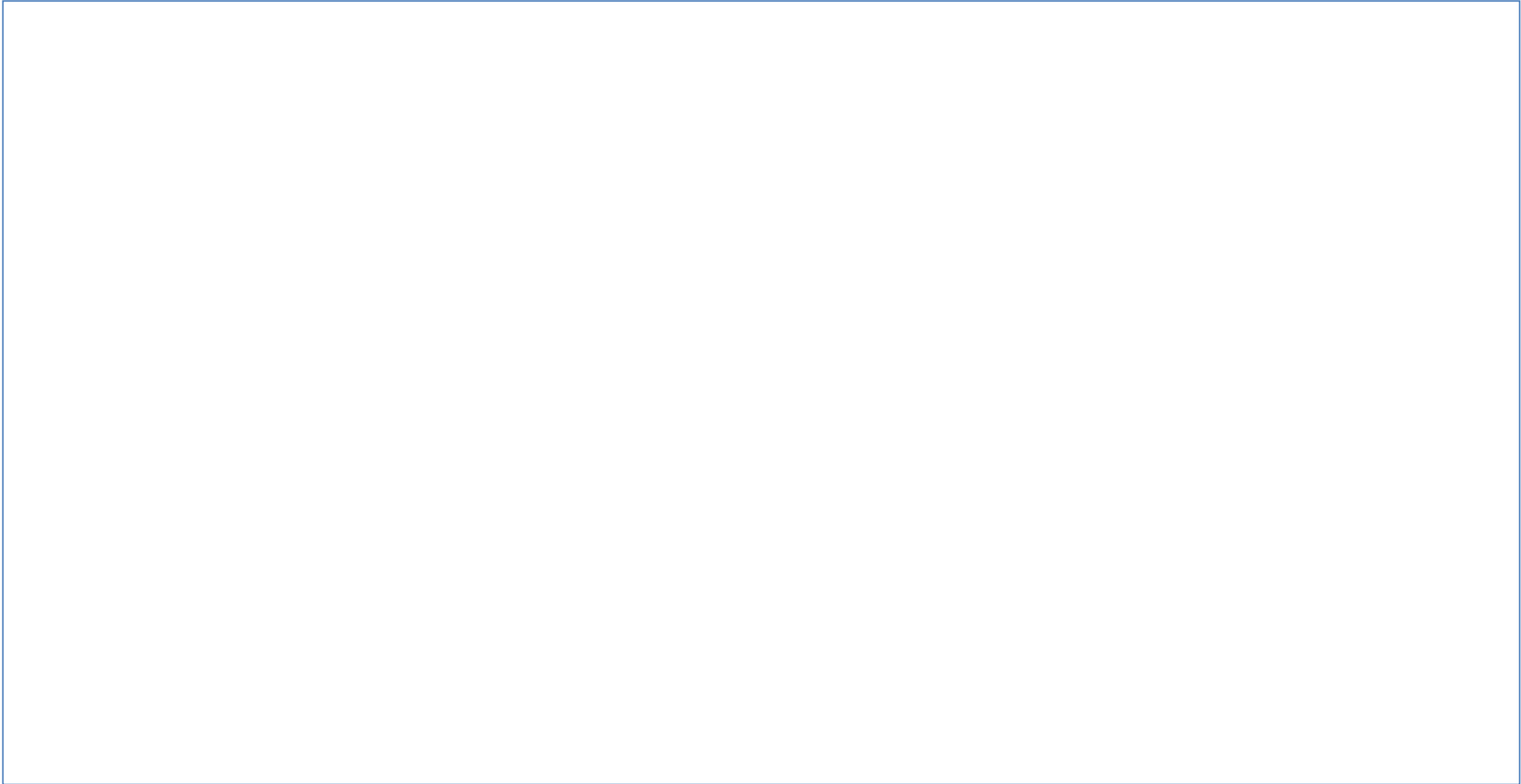

E.2. Wired Wall Pad

E.2.1. Wall Pad Display



E.2.2. Wall Pad Operation Guidelines

a) Clock display and setting

















System has an accurate internal real time clock used for time indication and timer ON/OFF function. Real time clock display area indicates internal time clock which can be set by  or  button.

b) Day display and setting









The wall pad has day display function which is used for day indication and timer ON/OFF function. Day display icon indicates current day. Press  button to set day.

c) Timer ON/OFF setting



If master unit is in global control mode and ON/OFF timer setting is reached, master unit will command the whole network to be on or off. Otherwise timer ON/OFF is effective to the local unit only. The system supports 7 days ON/OFF timer setting.



- Press  button once,  and  symbol blinking indicates ON timer programming mode, day display area indicates the day for setting timer on. If on timer for this day is null, timer display area shows , otherwise the ON timer setting will be shown. Press  or  button to change the ON timer setting. Press  key to cancel the current ON timer selected and the timer display area will show . Press  button to change the day the ON timer is to be programmed.
- Press  button again,  and  symbol blinking indicates OFF timer programming mode. The setting method is the same as ON timer setting above.
- Press  button again, to exit timer ON/OFF setting function.
- Should there be any on or off timer being programmed,  will light up. Should there be any unexecuted ON or OFF timer for the current day, its corresponding  or  icon will light up.
- Hold down  button for 3 seconds to cancel all timer settings.

d) Timer set by master unit is as follows:



- Press  button to enter into networking control mode. Unit area blinking indicates the slave unit under control. Press  or  to select the desired slave unit. Units that are off will be skipped automatically.
- Press  button once to enter into ON timer programming mode. Press  button to select the required day of the week. Master unit will then retrieve the setting from the selected slave unit and timer display area will show "rAd". The ON timer setting will be shown upon reading the data successfully. Press  or  button to change the ON timer setting.
- Press  button again to enter into OFF timer programming mode. Press  button to select the required day of the week. Master unit will then retrieve the setting from the selected slave unit and timer

display area will show “rEAd”. The OFF timer setting will be shown upon reading the data successfully.





Press  or  button to change the OFF timer setting.

- Upon completion of changing timer settings for the selected day, press  button again to exit timer programming mode. The settings will then upload to the selected slave unit. The next day of the week settings can be done only upon completion of sending data to the slave units. (Repeat steps 1~4 if setting is required for the next day of the week).
- In Global control mode:
- Pressing Master  button for 3 seconds will cancel all timer settings in all slave units.
- Timer settings will be broadcast to all slave units.

e) Clock synchronization by master unit is as follows:

Press  and  buttons for 3 seconds to activate clock synchronization to all slave units. Master wall pad will respond with a beeping sound.

f) Key lock

In order to prevent unauthorized access to the system setting, a key lock function is provided to prevent mischief. Hold down  and  for 3 seconds to activate key lock,  symbol lights up. Repeat the same to exit key lock. Only  button is applicable in key lock mode.



g) Swing

No applicable

h) Sleep

Press  button to activate or deactivate sleep setting. Sleep is valid in cool or heat mode only.

i) Temperature setting

Press  or  to enter into temperature setting mode, temperature display area blinks indicating the current set temperature. Press the above buttons to adjust the set temperature.

j) Mode setting

Press  button to change the operation mode.

k) Fan speed setting

Press  button to change the fan speed. Only low speed is available for dehumidification mode.

l) ON/OFF control

Press  to start or stop the air conditioner.

m) Networking Master - Slave Control (only master unit wall pad can control other units on the network)

- Press **NET** button to enter into networking control mode. Unit area blinking indicates the slave unit under control. Press **TIME** or **TIME** to select the desired slave unit; Units that are off will be bypassed automatically. Parameters that can be controlled are ON/OFF, Timer Weekly Program, Set Temperature, Mode, Fan Speed, Swing and Sleep. Parameter operation methods are the same as above. Press **NET** button again to exit networking control mode.
- Hold down **SWING** and **FRESH** buttons for 3 seconds to enter into global control mode,  lights up. Repeat the same to exit global control mode. In global control mode, the settings of the master unit will be broadcast to all the slave units.

n) Unit operation parameters browsing

Hold down **CANCEL** and **FAN** buttons for 3 seconds to enter into operation parameters browsing mode. Unit display area shows the slave unit under browsing. Slave unit selection method is the same as in networking

control above. Press **HUMIDIFY** or **HUMIDIFY** to browse various parameters as follow:

Wall pad display temperature area	Wall pad display time area
C0	Return air temperature displayed
C1	Indoor coil temperature displayed
C2	DIP switch setting displayed
C3	Indoor coil 2 temperature

Press **CANCEL** button to exit.

o) Error indication

When faulty slave unit is detected, Master unit display area shows the faulty unit address, time area shows the error code and wall pad backlight changes to red color. Should there be multiple units having problems, addresses and error codes will be shown one after another.

Error code definition:

Error	Error code
Electrical heater faulty	E1
Indoor coil sensor 2 faulty	E2
Return air sensor faulty	E3
Indoor coil sensor 1 faulty	E4
Indoor coil low temperature protection	E5
Indoor coil over heat protection	E6
Float switch alarm	E7
Local communication error	E8

For system without master-slave settings, wall pad will indicate unit error codes as above.

E.2.3. EC unit RPM setting

- 1) Turn Off the unit.
- 2) Open wall pad's back cover, two DIP switches are appeared.
- 3) Turn the DIP switch 1 to "ON" position.

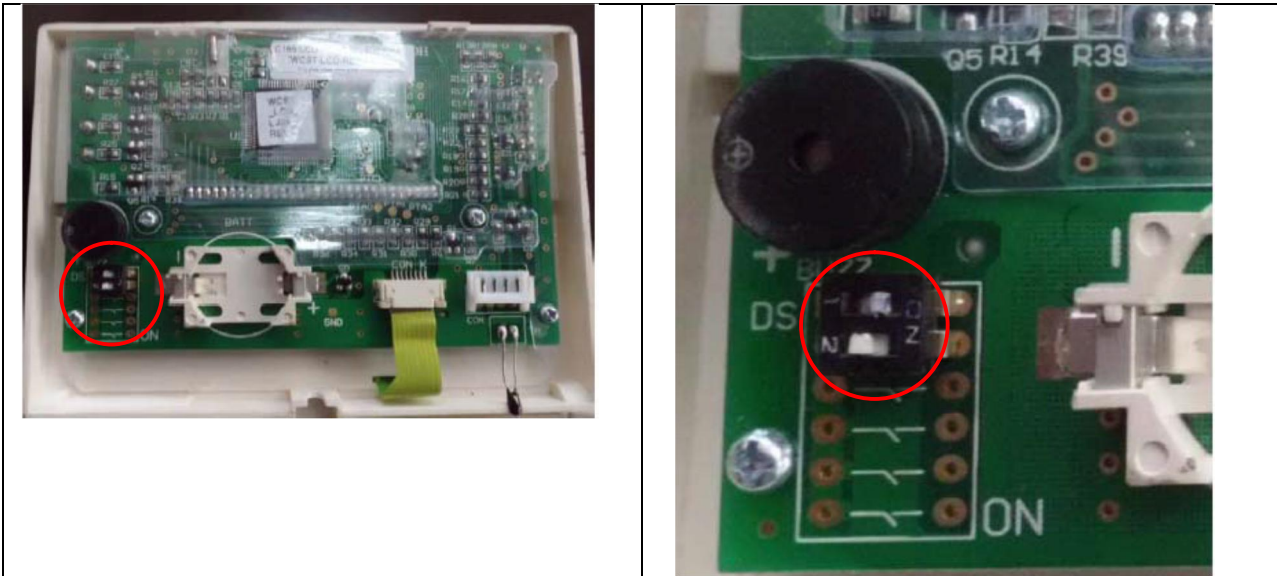

- 4) Wired wall pad LED will be shown as following;

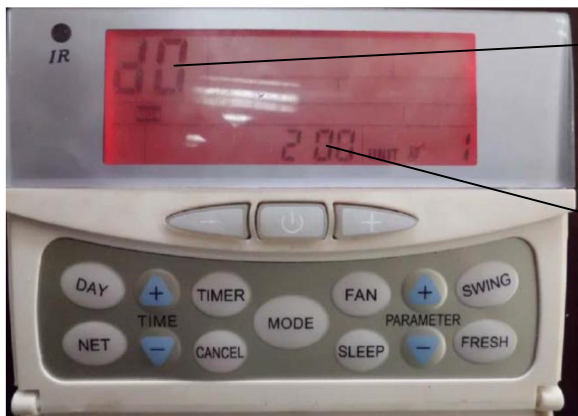

This is the speed level setting.
 d0 means low speed
 d1 means medium speed
 d2 means high speed
 Press PARAMETER + / - button to select.

This is the motor RPM setting.
 Press TEMP. + / - button to increase the
 RPM setting by 10RPM step.

- 5) After finish the RPM setting, turn the DIP switch 1 to "OFF" position. The Wired wall pad display will resume normal.

E.3. Sensor Resistance R-T Conversion Table

Resistance: $R(25^{\circ}\text{C}) = 10\text{K}\Omega \pm 1\%$

Beta Constant: $B(25/85) = 528\text{K} \pm 1\%$

T	Rmin (K Ω)	Rnom (K Ω)	Rmax (K Ω)	T	Rmin (K Ω)	Rnom (K Ω)	Rmax (K Ω)
-30	174	182.7	191.8	4	26.11	26.9	27.71
-29	163.4	171.5	179.9	5	24.85	25.59	26.34
-28	153.6	161.1	168.9	6	23.65	24.35	25.05
-27	144.4	151.3	158.5	7	22.52	23.17	23.83
-26	135.8	142.2	148.9	8	21.45	22.06	22.68
-25	127.8	133.8	140	9	20.44	21.01	21.59
-24	120.3	125.8	131.6	10	19.48	20.02	20.55
-23	113.3	118.4	123.8	11	18.58	19.7	19.58
-22	106.7	111.5	116.5	12	17.71	18.18	18.65
-21	100.6	105.1	109.7	13	16.9	17.33	17.77
-20	94.9	99.03	103.3	14	16.12	16.53	16.94
-19	89.51	93.39	97.41	15	15.39	15.77	16.16
-18	84.5	88.11	91.85	16	14.69	15.05	15.41
-17	79.8	83.17	86.64	17	14.03	14.37	14.7
-16	75.39	78.53	81.76	18	13.41	13.72	14.03
-15	71.26	74.18	77.19	19	12.81	13.1	13.4
-14	67.37	70.1	72.9	20	12.24	12.52	12.79
-13	63.73	66.26	68.88	21	11.7	11.96	12.22
-12	60.3	62.67	65.1	22	11.19	11.43	11.67
-11	57.08	59.28	61.55	23	10.71	10.93	11.15
-10	54.05	56.1	58.22	24	10.24	10.45	10.66
-9	51.19	53.12	55.08	25	9.8	10	10.2
-8	48.51	50.3	52.14	26	9.374	9.57	9.765
-7	45.98	47.66	49.37	27	8.969	9.16	9.351
-6	43.61	45.17	46.77	28	8.584	8.77	8.957
-5	41.36	42.82	44.31	29	8.218	8.4	8.582
-4	39.25	40.61	42	30	7.869	8.047	8.225
-3	37.26	38.53	39.83	31	7.537	7.71	7.885
-2	35.38	36.56	37.78	32	7.221	7.39	7.56
-1	33.6	34.71	35.85	33	6.92	7.085	7.251
0	31.93	32.97	34.02	34	6.633	6.794	6.956
1	30.35	31.32	32.3	35	6.36	6.517	6.675
2	28.85	29.76	30.68	36	6.099	6.252	6.407
3	27.44	28.29	29.15	37	5.85	6	6.151

T	Rmin (KΩ)	Rnom (KΩ)	Rmax (KΩ)	T	Rmin (KΩ)	Rnom (KΩ)	Rmax (KΩ)
38	5.614	5.759	5.907	75	1.417	1.474	1.532
39	5.387	5.53	5.673	76	1.37	1.426	1.482
40	5.172	5.31	5.451	77	1.326	1.379	1.434
41	4.966	5.101	5.238	78	1.282	1.335	1.389
42	4.769	4.901	5.034	79	1.241	1.292	1.344
43	4.582	4.71	4.84	80	1.201	1.25	1.302
44	4.402	4.527	4.654	81	1.162	1.211	1.261
45	4.231	4.353	4.477	82	1.125	1.172	1.221
46	4.067	4.186	4.307	83	1.089	1.135	1.183
47	3.911	4.027	4.144	84	1.055	1.1	1.146
48	3.761	3.874	3.989	85	1.021	1.065	1.111
49	3.618	3.728	3.84	86	0.9891	1.032	1.077
50	3.481	3.588	3.697	87	0.9582	1	1.044
51	3.35	3.454	3.561	88	0.9284	0.9697	1.012
52	3.225	3.326	3.43	89	0.8998	0.9401	0.9818
53	3.105	3.204	3.305	90	0.8721	0.9115	0.9522
54	2.99	3.086	3.185	91	0.8455	0.8839	0.9237
55	2.88	2.974	3.07	92	0.8198	0.8573	0.8961
56	2.774	2.866	2.959	93	0.795	0.8316	0.8696
57	2.673	2.762	2.854	94	0.7711	0.8069	0.8439
58	2.576	2.663	2.752	95	0.748	0.783	0.8192
59	2.483	2.568	2.655	96	0.7258	0.7599	0.7953
60	2.394	2.477	2.562	97	0.7043	0.7376	0.7722
61	2.309	2.39	2.472	98	0.6836	0.7161	0.7499
62	2.227	2.306	2.386	99	0.6635	0.6953	0.7283
63	2.149	2.225	2.304	100	0.6442	0.6752	0.7075
64	2.073	2.148	2.224	101	0.6255	0.6558	0.6874
65	2.001	2.074	2.148	102	0.6075	0.6371	0.6679
66	1.931	2.002	2.075	103	0.59	0.619	0.6491
67	1.865	1.934	2.005	104	0.5732	0.6015	0.631
68	1.801	1.868	1.937	105	0.5569	0.5846	0.6134
69	1.739	1.805	1.872				
70	1.68	1.744	1.81				
71	1.623	1.686	1.75				
72	1.569	1.63	1.692				
73	1.516	1.576	1.637				
74	1.466	1.524	1.583				

E.4. Troubleshooting Guide

